



BB KING INSPIRED

Guitar Lesson Series eBook

WRITTEN BY DAVID TAUB

Copyright © 2017 Next Level Guitar Inc., All rights reserved
Unauthorized replication or distribution strictly prohibited

Table of Contents

Table of contents.....	2
Introduction - BB King inspired lesson series.....	3
Things to keep in mind.....	4
Practice items & tips.....	5
Notes on the fretboard.....	6
Gear & Goals.....	7
The I-IV-V 12-Bar Blues.....	8
Lead Guitar - The Big Four.....	9
Key signature & chord analyzation.....	10
The choices when soloing.....	11
Minor key soloing.....	12
Minor key soloing theory.....	13
Major key soloing.....	14
The Five Jam Tracks.....	15-20
Scales defined.....	21
Minor pentatonic - the basic box shape.....	22
String bending in minor pentatonic.....	23
Minor pentatonic - the five box shapes.....	24
Minor pentatonic - the expanded scales.....	25
Minor pentatonic & blues - the five box shapes.....	26
Minor pentatonic & blues - the expanded scales.....	27
The major pentatonic scale.....	28-29
The major scale.....	30
Major scale links across the fretboard.....	31
The modes of the major scale - overview.....	32
The modes of the major scale - application.....	33-34
The modes of the major scale - Aeolian.....	35
The modes of the major scale - Lydian.....	36
The modes of the major scale - Phrygian.....	37
The modes of the major scale - Dorian.....	38
The modes of the major scale - Mixolydian.....	39
Soloing review tips.....	40
Words of encouragement from the author David Taub.....	41

The content throughout this eBook are guidelines, not necessarily rules forged in stone. Often you have to use your discretion when jamming and let your ear guide you. Remember, if it sounds good.....it is good.

Remember to experiment, be creative, and continually challenge yourself on the guitar. Be bold and try new things and eventually come up with other lead guitar avenues that work within your playing style.

Be sure to explore the coinciding jam tracks inspired by this style. Jam tracks are an invaluable tool for the practicing guitarist to work on application and to apply what you are learning in a musical situation. Practicing and playing along to jam tracks helps develop and hone your rhythm & timing, scale knowledge, technique, tone, creativity, musical awareness, and enhances your overall musical experience.

Keep in mind that after the theory, and the “why” things work, there needs to come a point when you take a break from learning theory and scales and just play music.

Music is so much more than just the logical application of theories and melodies. There is a human emotional element to music that you want to get across in your playing. So yes, practice and study up, but strike a balance, be inspired, and then just get out there and jam and have fun.

You know what I always say, “If it’s not fun.....why do it?”

Introduction to BB King inspired lessons

Hello, David Taub here from Next Level Guitar. Welcome to our BB King inspired lesson series. This course is a deep dive into the playing style and techniques of the king of the blues, Mr. BB King.

The course consists of this eBook, five jam tracks, and 15 HD video lessons. In these lessons you will learn all kinds of techniques, devices, scales, licks, and soloing strategies in the style of BB King.

BB King is considered one of the most influential blues musicians of all time. His music and guitar playing have had a profound influence across the world's musical landscape.

One can say that BB has defined the blues for a worldwide audience. He is a 15-time Grammy Award winner and he always ranks high on Rolling Stone magazine's list of the 100 greatest guitarists of all time.

Riley Ben King, known as BB King, was inducted into the Blues Hall Of Fame in 1980 and the Rock n Roll Hall Of Fame in 1987. His playing is always instantly identifiable and phrased impeccably well. All you need to hear is a few of his sweet notes or his stinging vibrato and you know its BB.

King's unique style always used his voice and guitar to provide melody and harmony. His technique was one of spareness and emotive playing. I remember him stating in an interview, "its not just the notes that you play, but also the notes you don't play". That statement resonated with me and I always remembered it.

He is often cited as being a huge playing influence of guitar players from all generations and musical styles. From classic guitar greats like Jimi Hendrix, Eric Clapton, Albert King, Stevie Ray Vaughn, Bonnie Raitt, and Albert Collins, to more modern blues players like Joe Bonamassa, Jon Mayer, Gary Clark Jr, and Bonnie Raitt. Even rappers have sampled Kings music like 50 Cent and Tony Yayo. Yayo sampled BB King's *Chains and Things*, and Ice Cube sampled King's *A Bird in the Hand*.

BB was one of the hardest working musicians in the business and he continued to tour all over the world well into his 80s. He averaged over his career playing at least 250 gigs annually. In 1956 he played a whopping 342 shows. King died at the age of 89 on May 14, 2015.

Be inspired, and mostly have fun while doing it. Enjoy these materials, stay positive and remember that your playing is an evolution that takes time and patience.

And please feel free to email us any questions.

“Music is good for everybody. They say it soothes the savage beast. Well, I think theirs a beast in all of us. So let's get some more music and soothe all the beasts out there.”
-BB King

“The beautiful thing about learning is nobody can take it away from you.”
-BB King

“Anyone could play a thousand notes and never say what BB can say in one.”
-Lenny Kravitz

"B.B. King has done the most for blues in the history of music"
-Bonnie Raitt

Things to keep in mind

Keep in mind that our teaching philosophy here at Next Level Guitar focuses on giving students a well rounded musical education. This does not mean you have to master every lead guitar avenue or scale before moving on to the next. You will want to work on multiple things at once by dividing up your practice time.

Throughout this eBook and video lessons series we teach many lead guitar avenues so feel free to hop around. Some are more challenging than others and take more time to learn and apply.

With practice, you will find the principles and techniques sink in and will eventually become automatic. Then you can let your ear take you to all the right notes. You won't have to think about techniques and application so much, but rather focus on emotion and feel.

It can be overwhelming with so much to learn and so many learning materials readily available. Try not to take on too much at once as you may become overwhelmed and frustrated. You don't want to rush things and then end up skimming over important topics leaving voids in your playing. Chip away a little each day and remember, it's not a race, it's a journey.

It's critical to take the extra time to learn "why" things work. Learning the "whys" will give you the musical knowledge to blast these principles and techniques across all your playing. It will give you the lead guitar confidence to be able to instantly know what avenues are possible when soloing and improvising.

Use these lessons as "templates" to learn the "whys" and then develop them into your guitar arsenal through practical application. Then you will have the tools and confidence to blast these playing techniques across all your playing at any given time, in any given key, in any given jam,

As you further develop your lead guitar skills you want to keep developing your rhythm skills. Your rhythm and groove are critical elements to your overall abilities on the guitar.

Your lead playing will really only ever be as good as your rhythm playing. No matter how good a solo is, it's the song that will always be remembered.

KEY POINT: Keep in mind that there is just no substitute for practicing the right things, learning scales, studying the sounds and relationships between chords and scales, developing your ear, practicing and honing your skills using jam tracks, and continually pushing yourself and refining your art.

Key Points:

Keep in mind not to neglect your rhythm playing. Your lead playing will only ever be as good as your rhythm playing.

Keep in mind that no matter how good a solo is....in the end it's the song that will be remembered.

Keep in mind to keep developing your ear. It's one of the most important and under-rated tools of the guitar player and musician.

Practice Items & Tips

Below are some general study avenues for rock and blues guitar. Because students of various levels will be reading this eBook these are broad jump off points for your consideration. Work down the list and see which you are comfortable with and which may need some work. Many of the below items will be addressed in detail throughout this eBook.

Remember your guitar playing is an evolution. Use some of the below items to set musical goals and then chip away at them a little each day. Set some goals, then get out there and achieve them!

- **Learn the notes on the neck** cold. No way around this one, it is super critical.

-As you study lead guitar, **continue to learn chords and work on your rhythm playing**. You will be playing rhythm often so your lead playing will really only ever be as good as your rhythm playing.

-**Learn some music theory**. It will help propel you faster along in your guitar journey as well as you will be able to better communicate the language of music.

-**Don't just learn scales alone**. Learn the scale but also learn how to apply it. Learn when it works, over what chords, and how to play it in all keys. Knowing the scale itself is only half the battle.

-Kick off your lead guitar journey by **learning the Minor Pentatonic scale**. Start with the basic box shape and then learn all five boxes and expanded scales. Pentatonic scales are the cornerstone for blues rock soloing.

-**Learn how to convert minor pentatonic scales into major pentatonic scales** by using the concept of major to relative minor. This is a huge help as you won't have to learn another full neck of scales.

-**Don't just learn shapes**. Take the extra time to learn the notes of the scales you are playing and the notes that are in chords. This will help you immensely in so many ways along your guitar journey.

-Be sure to know how to solo comfortably in **both minor AND major key**.

-**Always try to compliment the song with your lead lines**. Remember, no matter how good a solo is, in the end it's the song that will be remembered. Play for the song, not for yourself.

-**Learn some triads and arpeggios**. They really open up your playing, add color and variety, and get you out of playing straight scales. They are super useful and can be super melody builders.

-After you have a firm grasp on pentatonic scales and how to apply them start to **learn Major and Natural Minor Scales**. These are the building blocks to learn the modes of the major scale.

-**Learn the modes of the major scale**. For rock and blues playing start with Aeolian, Dorian, and Mixolydian.

-**Study and learn the leads of some of your favorite players**. Learn why their leads work and what you like about them. Then make their licks your own, put your own spin on them. Also try imitating the melody of a vocal line on your guitar. This really helps to understand and build melodies on the instrument.

-**Practice soloing and improvising over jam tracks**. Know the chords of the rhythm track and just get lost in it. It's critical to practice and apply what you are learning in a musical context. Jam tracks are both an invaluable practice tool and a lot of fun.

-**Develop your ear**, don't rely solely on tablature. Try to learn songs and licks by ear. Listen for the color of chords and try any ear training that you can get your hands on. It's hard work, but well worth it.

-**And remember.....you can't learn less!**

Notes On The Fretboard

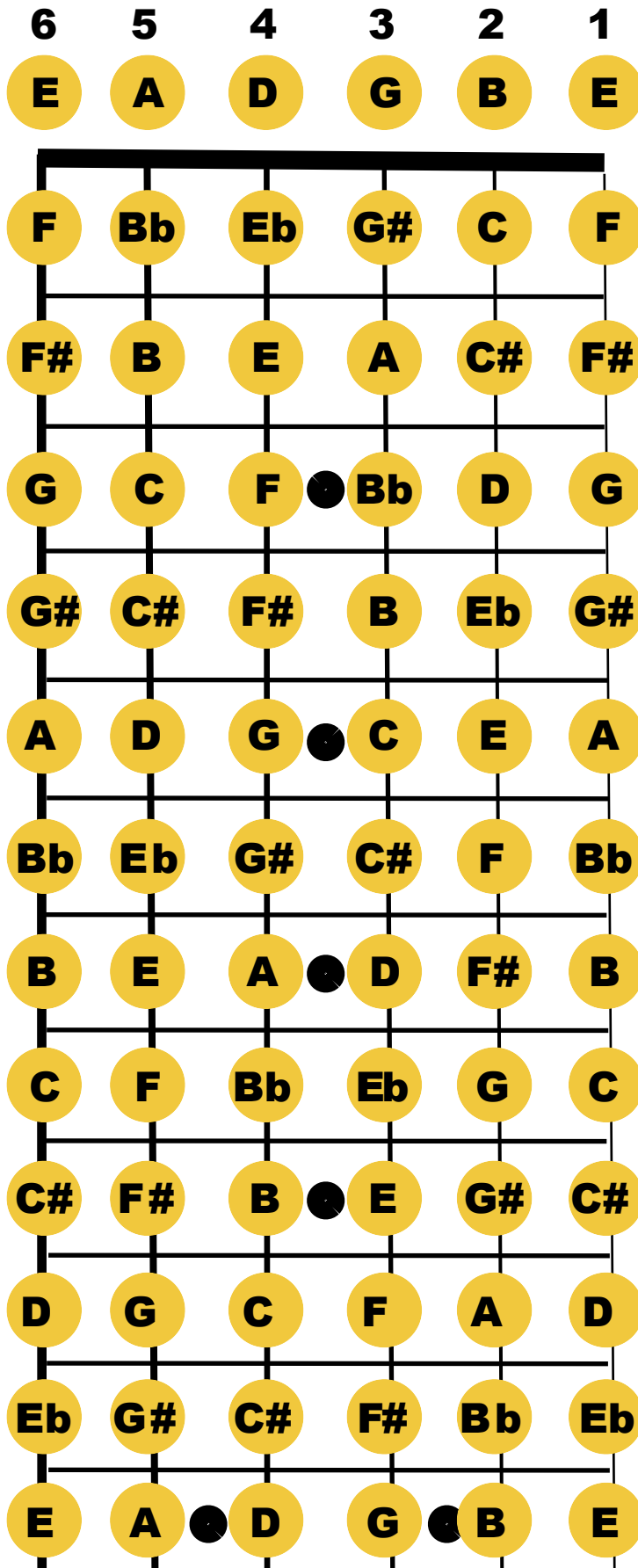

Open Strings

Eddie Ate Dynamite Good Bye Eddie

= Sharp

b = Flat

The twelve-note scale consists of:

A, Bb, B, C, C#, D, Eb, E, F, F#, G, G#

Memorize the order of the 12-note scale as the notes always appear on the guitar neck in the above order.

Examine the notes along one string vertically. Notice how the notes always repeat in this same order. The notes then repeat every 12 frets.

Once you have the 12-note scale memorized start applying it to the frets on the guitar and memorizing where the notes live on the fretboard.

Take it slow and work on one string at a time. Start with the low E string. Once you memorize that string you will also know the note names on the high E string as the note names on those two strings are the same.

Once you have the E strings memorized then move on to the A string, then the D string, and so on. Chip away at getting each string down a little each day. Add learning the notes to your daily practice regimen - you can do it!

Gear & Goals

Lead guitar playing is something that can identify a player like a signature or fingerprint. Players like BB King, Stevie Ray Vaughan, Eddie Van Halen, David Gilmour, Joe Satriani, Eric Clapton, Eric Johnson, Steve Vai, and Carlos Santana can be identified with a single note. They have a very signature tone.

As you continue your lead guitar studies and practicing, you will find your playing will evolve over time, your playing is an evolution. An element of lead playing which may seem simple, like vibrato or string bending, can take months and months to develop into a signature statement in your lead guitar bag of tricks.

GEAR/EQUIPMENT – Sometimes guitarists think that if they purchase the same guitar, amp, and effects of their favorite player that they will cop their signature sound and replicate their tone. You will find that this is not the case. Here is a quick story to illustrate this point.

When Van Halen was first starting out they opened for some name acts of the time. Eddie Van Halen was so revolutionary with his guitar playing that he virtually floored the guitar community. One show Van Halen was opening for Ted Nugent and Ted watched in amazement as Eddie played during sound check. Ted couldn't believe the sounds he was hearing. After Eddie left the stage Ted then talked Eddie's guitar tech into letting him plug into Eddie's rig. Ted Nugent started playing through Eddie's gear and guess what.....he sounded like Ted Nugent.

The point is that your tone comes mainly from your fingers and your technique, not the amp or effect. Tone is truly in your hands and in your heart. Also how you attack the strings and what you do to the notes plays a huge part in your tone.

Gear can surely be motivating and empowering and point you in a certain direction, but ultimately your tone is in your hands.

Eddie Van Halen can play any guitar through any amp and will still sound like Eddie Van Halen. You want to play through the best gear that you can afford, but spend time developing your own technique and sound and don't get too lost trying to copy someone else's.

Accomplish two things when soloing and improvising:

1. Complement the song – it all comes back to the song and how the guitar lines complement it and help to get its musical statement and emotions across. As great as a guitar solo can be,.....in the end,.....it's the song that will be remembered. Play for the song, not for yourself.

2. Draw people in to your solo – you want the listener to latch onto what you are playing. You want to keep the listener on the edge of their seat wondering, "what is he going to play next"? You want to have the power to take the listener on a musical journey with ups and downs and great emotion and passion. You want your leads to tell a story.

Be aware of melody happening within in your guitar lines. At times many guitarists forget the above two items and are off soloing in their own "little world". They forget about the song, the chord changes, melody, and what the other musicians behind them are doing. Then the song suffers and the band has to "reel" the guitarist back into the groove.

The I-IV-V 12-Bar Blues

It's critical to analyze and understand the chords you are playing over in order to get the full roadmap of soloing avenues. It's the chords that give the complete lead guitar and improvisation scenario. The key signature only gives you one piece of the puzzle.

You need to know what are the chords in the progression, when are chords changing, and how much musical time, or measures, are spent on each chord. This way you can play both the proper rhythm structure, and also know all available lead guitar avenues. Understanding the chords within the rhythmic structure of the song is crucial.

There are many types of blues rhythms. The most common is the I-IV-V 12-bar. Most of the jam tracks included in this course fall within the 12-bar pattern.

The "12-bar" means that the song is divided into 12 parts or measures. Then you just keep repeating that same 12-bar pattern over and over. Other common blues progressions are 8-bar, 16-bar, and 24-bar blues.

Two of the most common 12 bar patterns are the slow change and the fast change. You will need to be VERY familiar with both. The only difference between the two is the second measure. The slow change stays on the I chord for 4 bars at first while the fast change at goes from one bar on the one chord to one bar on the four chord then back to the one chord for two bars, (see diagram below).

12-Bar Slow Change:

Measure:	1	2	3	4	5	6	7	8	9	10	11	12
Chord:	I	I	I	I	IV	IV	I	I	V	IV	I	V

12-Bar Fast Change:

Measure:	1	2	3	4	5	6	7	8	9	10	11	12
Chord:	I	IV	I	I	IV	IV	I	I	V	IV	I	IV

The fast change is often used for slower tempo blues. With a little practice you will soon know the patterns by heart and can whip them out instantly, they will become automatic.

These instantly recognizable 12-bar patterns are the rhythmic standards, the meat and potatoes of the blues. Ever wonder why any group of blues musicians can just sit down together and instantly play with a vibe? It's because of these standard progressions that are so common in blues music. Everyone knows these and they are ingrained in the musicians' musical DNA. Just like how many classic rock ballads were constructed from I-IV-V progressions.

I suggest practicing rhythm by playing the rhythms to jam tracks. This will dial in your rhythm chops as well as help develop your ear. Feel the changes and how long you are on each chord. It won't take long before you get the hang of these standard blues progressions.

Your rhythm playing, timing, and groove is absolutely critical, so do not neglect it. I see that mistake made by guitar players over and over again. They focus too much on lead playing and not enough on rhythm playing. You want to be able to totally lock in with a rhythm section and nail the feel or groove. Remember that in most instances you will be playing rhythm guitar way more than you will be playing lead guitar. So don't neglect your rhythm chops.

Lead Guitar - The Big Four

Below are four critical parts to great lead playing. Work on all four of these aspects by studying each individually, and then apply them in a musical context by practicing over jam tracks.

1. Rhythm – the rhythm of your notes and licks. The way we take the notes we choose and do musically interesting things with them. This quite possibly could be one of the most important elements of lead guitar. Within the rhythm of your soloing, repetition is one key component and melody is another.

Repetition is a key to good melody and phrasing. You don't have to play your licks verbatim every time in a lead line, but rather the same in concept. Noodle around on the guitar till you find a killer sounding riff or lick. Then dig into that idea and keep repeating it. Repeat it, but try playing it a little different rhythmically each time or maybe hit the same note a different number of times, or slide into the notes, or do a bend one time, vary it, change the notes a little. These variations give you tons of licks and ideas born from the same musical theme.

Learn to vary your licks both note wise and rhythm wise. Learn a rhythm or rhythmic phrase and then apply it to some of your favorite licks across all the strings. So when you noodle around and get into a little cool idea, keep it.....keep playing it and turn the rhythm around and exploit it. Remember rhythm and melody are key!

2. The Ride – the musical ups and downs. The peaks and valleys, the highs and lows and dynamics in your soloing. It's the way your lines move up and down the neck and get loud and soft. You just don't want to be rambling on and on with straight across the board flat line playing of nothing but streams and streams of notes.....blah, blah, blah. Remember that nobody likes the guy that talks too much.

You want to move your listeners and draw them into your solo. Your solo should have ups and downs, peaks and valleys, and twists and turns. You don't want just flat straight lines with no dynamics, emphasis, different rhythms, or sans any musical events or melody.

3. Note choice – this may seem pretty obvious but which notes you play are equally as important as which notes you don't play. For example, if you are playing the blues you have only have five or six main notes to choose from so note choices are limited. So you better have a very big rhythm and ride bag of tricks because that is what is going to make your lead lines sound interesting.

4. Phrasing – Basically a phrase is a group of notes that compose a musical thought. Phrasing is all about how you connect your notes, scales, ideas, and licks into musical sounding lines. You want to connect your groups of phrases in a manner that makes good musical sense.

When you don't have a lot of note choices then you really have to concentrate on your phrasing to keep things interesting. Some players really excel at phrasing and it's very clear when someone is good at it as the music just flows out of them effortlessly.

Listen to the playing of Stevie Ray Vaughan, the music just flowed out of him. It's almost like he had a direct channel between his brain, heart, and fingers.

His playing was smooth and fluid with his musical thoughts and ideas phrasing effortlessly into one another.

Work on your own personal channel and musical connections. Think melodically and vary your lick ideas. Practice over jam tracks and keep refining your art.

Key signature & chord analyzing

In rock and blues you will often solo over progressions that are in either major key or minor key. In blues usually its major key and often using dominant chords. But you want to have the tools to be able to solo over both major and minor key.

Knowing the key is important, and a good place to start. But to go deeper you have to analyze the chords that make up the progression to get the complete roadmap for soloing options. Always start with what are the chords and what is the key.

Soon these techniques will become automatic. But first applying these concepts in a systematic and methodical approach will get you used to these devices.

Remember there are many lead guitar avenues to choose from, so explore them all and see what sounds best to your ears.

KEY POINT: Analyze the chords to determine what are the soloing avenues. It's the chords that give the complete roadmap, the key signature is only part of the equation.

It's important to understand why these principles and techniques work so that you can solo and improvise over any song or jam. Armed with this knowledge and practicing in a musical context will give you the lead guitar confidence to solo over any progression.

KEY POINT: Remember that as soon as you hear that very identifiable major I-IV-V blues, swing, or shuffle, it is wide open and there will be many different soloing avenues to try.

Minor Pentatonic & Blues Scales - four great applications:

1. Over all chords in minor key (except a major V chord).
2. Over any minor type chord when treating each chord as a separate event.
3. Over all the chords in major key I-IV-V blues jams, swings, and shuffles.
4. Over all the chords in rock jams or jams using power or 5th chords, (except major sounding jams and ballads).

Soloing in minor key:

When playing over all the chords in minor key, what *"relates to all"*, you can always use Natural Minor Scales, (Aeolian Mode), UNLESS there is a major IV chord or a minor ii chord, in those cases use the Dorian Mode.

Key Points To Determine Soloing Avenues:

1. **Determine the key signature** - often you will be soloing in minor key or major key. Knowing the key is the first step. Even when you are just noodling around on the guitar, always know in what key you are playing.
2. **Analyze the chord progression** – it's the chords that will give you the complete roadmap to what you can utilize for soloing and improvisation. Analyzing the chords is a critical step to get the full lead guitar picture.

The concepts listed throughout these materials are guidelines to get you started, not rules forged in stone. Often you have to use your discretion. You want to learn the principles and techniques so you have a solid jump off point. Then you can get creative and start bending the rules as you develop your own style.

Analyze the chords as it's always the chords that will give you the complete roadmap to what you can utilize for soloing and improvisation

The Choices When Soloing:

When soloing/improvising there are TWO CHOICES:

1. Solo with what “relates to all” – use the same scale or mode over all the chords. No matter what chord is sounding, play the same scale over each chord. You play what works over ALL the chords.

This is the most common choice and definitely what most players do when first developing their soloing skills. Start with what “relates to all”. Get proficient at this before moving on to the next choice described below.

Or you can:

2. Treat each chord like a “separate event” - this choice is more challenging but yields a very sophisticated sound. By treating each chord as a separate event you solo with a different scale or mode over each chord and change the scale or mode with each chord change. This technique does not stay within the confines of the same scale as with what “relates to all”.

With this approach you must listen to what is going on underneath the soloing. You have to listen to which chords are sounding and also for the changes. Then time your playing and change scales as the chords change.

Employ this technique whenever there is enough time on a given chord. If the chords are flying by fast, there won't be enough time to treat each chord as a “separate event”.

This technique takes practice but it will skyrocket your playing to the next level. Practice this technique with slow tempo progressions where there is lots of time on each chord and remember to listen for the changes.

At first practice with the coinciding jam tracks that have slow moving changes to perfect this technique. You want lots of time on each chord.

KEY POINT: The above two choices are **NOT** mutually exclusive, you can mix them both together. Treat each chord as a “separate event”, then switch it up and play what “relates to all”. Toggle back and forth and get lost exploring the possibilities within the jam tracks. And give yourself plenty of “fun time” on that guitar!

KEY POINTS:

There is no substitute for learning scales and studying the sounds and relationships between chords and scales.

Keep developing your ear and practice using jam tracks. Continually push yourself to the next level. Stay positive and remember..... YOU CAN DO IT!

Minor Key Soloing

You want to be comfortable soloing in both minor key and major key. If a progression is in minor key you can usually solo with Minor Pentatonic & Blues Scales over ALL the chords, (with a few exceptions).

So minor pentatonic over minor key should be a default setting. As soon as you hear or see minor key, you know one option is to solo over all the chords with Minor Pentatonic & Blues Scales as they “*relate to all*”.

Also if it’s a major key bluesy I-IV-V progression, one option is to solo over all the chords with Minor Pentatonic & Blues scales. An exception to this rule is if it’s a minor key progression with a major V chord. You have to be careful over that major V, one option is to use Harmonic Minor Scale over just that V chord.

A minor mode will also work over all the chords in minor key. Usually it’s Aeolian or Dorian. To determine which one you have to analyze the chords. For now just memorize the below key point for soloing in minor key over all the chords:

KEY POINT: When playing over all the chords in minor key you can use the AEOLIAN mode, UNLESS there is a IV major chord or ii minor chord, then use the DORIAN mode. (Exception - If there is a V major chord then use Harmonic Minor over the V chord).

Aeolian mode is the same thing as Natural Minor or Pure Minor.

Use Minor Pentatonic & Blues Scales (5 applications):

1. Over all the chords in a minor key, (few exceptions).
2. Over all chords in major key I-IV-V blues, shuffles, and swings.
3. Over any minor type chord when treating each chord as a “*separate event*”.
4. Over all the chords in rock type jams, or jams using power or 5th chords, (as long as the jam is not ballad/major sounding, if so then use major pentatonic or possibly full major scales).
5. Use the same key Pentatonic scale over different chords. At times you can play different key pentatonic scales over the same chord, not just the root scale. See the jam track application suggestions later in this eBook for more info on this technique.

Minor Pentatonic & Blues Scales - five great applications:

1. Over all chords in minor key (except a major V chord).
2. Over any minor type chord when treating each chord as a separate event.
3. Over all the chords in major key I-IV-V blues jams, swings, and shuffles.
4. Over all the chords in rock jams or jams using power or 5th chords, (except major sounding jams and ballads).
5. Use the same key Pentatonic scale over different chords. At times you can play different key pentatonic scales over the same chord, not just the root Pentatonic scale.

Soloing in minor key:

When playing over all the chords in minor key, what “*relates to all*”, you can always use Natural Minor Scales, (Aeolian Mode), UNLESS there is a major IV chord or a minor ii chord, in those cases use the Dorian Mode.

Minor Key Soloing Theory

In rock and blues you will often be soloing in minor key. So let's take a little extra time to dig deeper into some minor key soloing theory.

Let's first discuss minor key soloing with what "*relates to all*". When soloing in minor key, minor pentatonic and blues should be your default setting. In a minor key progression, you can utilize minor pentatonic and blues over all the chords as it "*relates to all*", (unless there is a major V chord).

When soloing in minor key usually a minor mode also "*relates to all*", usually Aeolian or Dorian. To know which one to play over all the chords there is one principle that you need to memorize:

****When playing over all the chords in minor key, use the AEOLIAN mode...UNLESS the IV chord is major or the ii chord is minor, then use the DORIAN mode.**

So in minor key over all the chords think minor pentatonic & blues as well as Aeolian unless you see a major IV or minor ii chord. An exception to this rule is if there is a major V chord, then you can try using the Harmonic Minor Scale over just the major V chord.

There is only a one note difference between the Dorian and Aeolian modes - the sixth. Aeolian has a b6 while Dorian has a major 6th:

AEOLIAN MODE: 1, 2, b3, 4, 5, b6, b7

DORIAN MODE: 1, 2, b3, 4, 5, 6, b7

If you hit the wrong sixth note over the corresponding chord it will sound sour, so it's super important you play the right mode over all the chords.

Remember we are talking about playing over all the chords in a minor key progression, playing what "*relates to all*".

One critical key in unlocking all the potential of these scales and modes is in learning their interval structure and memorizing the key points listed throughout this eBook. This way you will know when it is appropriate to apply each in a given soloing or improvisation scenario.

Another key is listening and studying the relationships between chords and scales and understanding which mood or emotion you want to apply. It's all about the sounds and what emotion and mood you want to get across in your playing.

That's the beauty of the modes, each have their own unique mood. More on the modes and modal playing application later in this eBook, stay tuned!

KEY POINTS:

When soloing in minor key you can often use a minor mode over all the chords. Use Aeolian Mode UNLESS the IV chord is major or the ii chord is minor, then use the Dorian Mode.

Analyze the chords to determine the soloing avenues. It's the CHORDS that give the full roadmap to the various soloing

Never forget the importance of listening and studying the relationships between chords and scales. It's all about the sounds and which moods you want to create with your playing.

Major Key Soloing

You want to get comfortable soloing in both minor key and major key. If a progression is in major key one choice is you can usually solo using Major Pentatonic scales over ALL the chords.

So major pentatonic over major key should be a default setting just like minor pentatonic over minor key. As soon as you hear major key, you know one option is to solo over all the chords with Major Pentatonic, as it *“relates to all”* the chords.

Major pentatonic produces that sweet, bright, major sound. Be sure to play the scale and listen to the sounds created. Its a very different sound than the bluesy Minor Pentatonic scale. Like I always say, its all about the sounds and mood.

MAJOR KEY I-IV-V blues, shuffles, and swings:

You will hear these rhythms all the time in blues music. If a progression is a major key I-IV-V blues, swing, or shuffle there are MANY avenues to utilize when soloing and improvising, it's wide open.

You can solo with what *“relates to all”* and also by treating each chord as a *“separate event”*. Here are some suggestions to try over these type very common progressions:

1. Try **Minor Pentatonic & Blues** scales over all the chords in the key of the progression. This yields that dark, bluesy, minor sound. (Minor Pentatonic & Blues – 1,b3,4,b5,5,b7)
2. Try **Major Pentatonic** scales over all the chords in the key of the progression. This produces that sweet major sound ala BB King/Allman Brothers. This will be a totally different sound than Minor Pentatonic. (Major Pentatonic – 1,2,3,5,6)
3. **Mix Minor Pentatonic & Blues and Major Pentatonic.** You will hear this a lot in the lead playing of Eric Clapton and BB King. The switching and mixing of Minor and Major Pentatonic is an awesome sound. (Minor & Major Pentatonic 1,2,b3,3,4,5,6,b7)
4. Try the **Dorian Mode** over all the chords. Dorian is the second mode of the major scale. It is considered more of a minor mode but it's intervals have elements of both minor, (b3, b7), and major (2nd, 6th). Dorian works great in any situation where you know both Minor Pentatonic and Major Pentatonic will work. Give it a try over I-IV-V blues progressions, its killer! (Dorian Mode – 1,2,b3,4,5,6,b7)
5. Try the **Mixolydian Mode** as it works great over dominant chords like 7th and 9th chords. Try to play this mode over each chord independently in the key of the chord. (Mixolydian Mode is the fifth mode of the major scale – 1,2,3,4,5,6,b7).

Major Pentatonic Scale applications:

1. Over all chords when in a major key.
2. Over any major type chord when treating each chord as a separate event. (especially dominant 7th chords in blues jams - very popular choice).
3. Over all the chords in major key I-IV-V blues jams, swings, and shuffles.
4. Over all the chords in rock major sounding jams and especially major ballads.
5. Use the same key major Pentatonic scale over different chords. At times you can play different key major pentatonic scales over the same chord, not just the root Pentatonic scale.

Soloing in major key:

Be careful as there is not as much room for error in major key and *“sour”* notes will really stick out. You can at times combine major pentatonic with minor pentatonic to produce hybrid scales with elements of both minor and major.

The Five Jam Tracks

This course comes with five Jam Tracks that are utilized throughout the video lessons. The tracks were designed as practice tools for learning and exploring the sounds and moods that can be created by utilizing various scales and modes in this style of play.

The tracks are wide open so there are a TON of different soloing and improvisational avenues to explore over each track. In the coming pages, we go over the tracks one by one and explain various soloing avenues and why they work.

Practicing in a musical situation, like over jam tracks, is a critical part of your soloing and improvisational growth as a guitar player. Often in jamming there is lots of room for improvisation and creativity. You have to use your discretion and determine what sounds best to your ears. Only you can determine which sounds and moods that you like best.

Keep in mind to analyze the chords that make up each track. It's the chords that give the complete roadmap to all the soloing and improvisation avenues. Like I always say there is just no substitute for studying the sounds and relationships between chords and scales and developing your ear.

You will want to try all the different moods and textures that can be created and see which you like best. Practicing and playing along to jam tracks helps develop and hone your rhythm & timing, scale knowledge, technique, tone, creativity, musical awareness, and enhances your overall musical experience.

To get the complete solo picture, it's the chords that give you the full roadmap to what to try when soloing and improvising. Get in the habit of always analyzing the chords.

Remember when soloing you have two options. The first is playing what "*relates to all*". And the second is treating each chord as a "*separate event*". Playing over each chord independently is more challenging than playing what "*relates to all*" as you have to listen for the chord changes and change your scale, mode, or arpeggio as the chords change. It is challenging, but yields a more sophisticated sound.

Don't worry if you don't know all the options listed for the tracks in the coming pages. Try what you are comfortable with at this point in your guitar journey and the other options can be attempted down the road. If you are not sure of the scales listed for each track, they are diagrammed out in the coming pages of this eBook.

The five jam tracks in this series:

1. E Slow Blues Jam Track
2. G Minor Blues Jam Track
3. G 12-Bar Blues Jam Track
4. C 12-Bar Blues Jam Track
5. King Inspired B Minor Jam Track

E Slow Blues Jam Track

In this jam track the chords are E - A - B7. The track is a slow blues jam in the key of E. The progression is a I-IV-V, 12-Bar Blues with a slow change to the IV chord. This track is a very slow tempo blues with lots of time on each chord if you to choose to solo by treating each chord as a separate event. Also refer to the coinciding video lessons for in depth studies on jamming over this track.

What Relates to all the chords:

-For the bluesy minor sound try E Minor Pentatonic & Blues over all the chords.

-For that sweet major sound try E Major Pentatonic over all the chords. E Major Pentatonic is the same as C# Minor Pentatonic. E Major and C# Minor are relative major and minor. If you think more in terms of Minor Pentatonic or you just know those shapes, then play all your C# Minor Pentatonic scales, but start on and emphasize the E notes and it will be E Major Pentatonic. This will have that real major happy sweet sound.

-Try E Dorian. Dorian is the 2nd mode in any major key. So ask yourself what major scales' 2nd note is an E. The answer is D. So E Dorian is the same as D major, (E Dorian=D major). Play all your D major scales but emphasize and start on the E notes. Resolve to and focus on those E notes and you are playing in E Dorian.

-Mix both E Minor Pentatonic, E Major Pentatonic, and E Dorian over all the chords for some killer sounds.

Treat each chord like a separate event:

In this jam the chords are moving slowly so you have a lot of time on each chord. This is perfect for treating each chord as a separate event. Remember to listen to the rhythm and time your changes so you change your scale or landing notes as the chords change. Here are a few avenues to try.

-Move Minor Pentatonic & Blues over each chord. Play E Minor Pentatonic & Blues over the E chord, A Minor Pentatonic & Blues over the A chord, and B Minor Pentatonic & Blues over the B7 chord.

-Move Major Pentatonic over each chord. Play E Major Pentatonic over the E chord, A Major Pentatonic over the A chord and B Major Pentatonic over the B7 chord.

-Mix up the above Minor Pentatonic and Major Pentatonic over each chord. Play E Major Pentatonic over the E chord or I chord and then then switch to E Minor Pentatonic & Blues over the A chord or IV chord. Then try E Major Pentatonic over the B7 chord or V chord. Listen to how well this technique outlines and implies the chord changes.

-Try B Mixolydian over the B7 chord. Remember that Mixolydian is the mode of choice when soloing over 7th and 9th chords. Mixolydian is the 5th mode of the major scale. Ask yourself what major scales' 5th note is a B? The answer is E. B Mixolydian=E major. Play E major scales and licks but start on and emphasize the B notes and you are now playing in B Mixolydian.

G Minor Blues Jam Track

In this jam track the chords are Gm7 - Cm7 - Eb - D, and the turnaround is on D7#9. This track is in the key of G minor. This track is not the easily identifiable major key standard 12-bar I-IV-V blues like the previous jam track and so many blues progressions. So we have to analyze the chords further and think more in minor key terms.

Note that in this track the chords are moving by fairly slow, so it's a great jam for treating each chord as a separate event. Remember that if the chords are flying by very fast you don't have enough time to solo on each chord independently. In those cases you would be playing more of what relates to all. Also refer to the coinciding video lessons for in depth studies on jamming over this track.

What Relates to all the chords:

-For the bluesy minor sound try G Minor Pentatonic & Blues over most of the chords. So whether you are playing over the Gm7, Cm7, or Eb chords, play G Minor Pentatonic & Blues scales all day long in this jam. But be careful around the D major chord as that is a V major chord in a minor key progression. We are in a minor key jam but it has a major V chord. The D chord moves by pretty fast so if you are careful you can steer around it while using Minor Pentatonic & Blues.

The issue is that the D major chord is made of the notes D, F#, A. So the chord really wants to resolve to that F# note and not necessarily the G note. Gm is the tonality we are playing in with G Minor Pentatonic. So just be cognizant of which notes you are landing on over the D chord and try to not hang on the F# note while on that D chord, try to just roll it up a half step to G. It will resolve better on that one chord. Also, be sure to try another option on just that D chord as listed below.

-Try G Aeolian (G Natural Minor) over all the chords. In minor key, a minor mode usually relates to all the chords. So we can usually play a minor mode over all the chords. Since we are in a minor key jam and when analyzing the chords the iv chord is minor, Cm7, then this tells us we can play G Aeolian mode, (G Natural Minor), over all the chords. Aeolian mode intervals are 1,2,b3,4,5,b6,b7. G minor is the relative minor of Bb major. So, play all your Bb major scales, but to make them G Aeolian, start on and emphasize the G notes, G Aeolian = Bb major. Remember to keep resolving your licks to those G notes.

-Mix both G Aeolian and G Minor Pentatonic & Blues over all the chords for some killer sounds.

Treat each chord as a separate event:

In this jam the chords are slow moving with lots of time on most of the chords, so here is a great opportunity to treat each chord as a separate event.

-Over the Gm7 chord try G Minor Pentatonic & Blues, G Aeolian, G Dorian, or G minor arpeggios.

-Over the Cm7 chord try C Minor Pentatonic & Blues, C Aeolian, C Dorian or C minor arpeggios.

-Over the Eb chord try some Eb major licks or an Eb major arpeggio.

-Over the D chord try some D major licks or a D major arpeggio, or G Harmonic Minor. Harmonic Minor works awesome over the V chord in a minor key progression. The keynote in the Harmonic Minor Scale is the major 7th and it's located one half step behind the root. You get great tension and release playing that 7th and then going up a half step resolving to the root.

***Note** - remember you don't have a lot of time on the Eb and D chords in this jam, just enough to rip a cool major lick or arpeggio over each chord. Be sure to get off in time when the chords change so you don't get caught playing the wrong scale in the wrong key over the wrong chord.

G 12-Bar Blues Jam Track

In this jam track the chords are G - C - D. This track is a traditional I-IV-V 12-bar blues in the key of G and has many soloing options. Like many blues jams this one starts off on the V chord. This jam features a pinky embellishment on each chord adding the 6th to each chord. Again, a very traditional blues rhythm device being employed. Also refer to the coinciding video lessons for in depth studies on jamming over this track.

What Relates to all the chords:

-For that bluesy minor sound try G Minor Pentatonic & Blues over all the chords. Since this is a major I-IV-V blues progression minor pentatonic & blues produces killer bluesy sounds. This will often be the first choice for many blues players on this type of jam. Try playing G minor pentatonic and blues scales over all the chords.

-For that sweet major sound try G Major Pentatonic over all the chords. If you think more in terms of minor pentatonic just use the concept of major and relative minor. G Major Pentatonic is the same as E minor Pentatonic. G Major and E minor are relative major and minor. So play E Minor Pentatonic scales, but start on and emphasize the G notes and it will be G Major Pentatonic. Keep resolving to the G notes.

-Try G Dorian over all the chords. Because we know that both major pentatonic & minor pentatonic will work we then know that the Dorian mode will also work. G Dorian is the same as F major, G Dorian=F major. So play F major scales but start on and emphasize the G notes for G Dorian sounds.

-Try mixing G Minor Pentatonic & Blues, G Major Pentatonic, and G Dorian over all the chords.

Treat each chord like a separate event:

With this 12-bar pattern there is not as much time on each chord as some of the slower jam tracks. But there is enough time on each chord to treat each chord as a separate event if you are quick. Just time your changes over each chord and really listen to the rhythm to ensure you don't get caught playing the wrong scale or in the wrong key over a given chord.

-Try moving Pentatonics over each chord. Over the G chord play G Minor Pentatonic & Blues or G Major Pentatonic, over the C chord play C Minor Pentatonic & Blues or C Major Pentatonic, and over the D chord play D Minor Pentatonic & Blues or D Major Pentatonic.

-Move the Dorian mode over each chord. Because the rhythm of this jam is embellished with the 6th, Dorian is a perfect choice for each chord as that is a very key interval in the mode, Dorian intervals are 1,2,b3,4,,5,6,b7. So try playing G Dorian (=F major) over the G chord, play C Dorian (=Bb major) over the C chord and play D Dorian (=C major) over the D chord.

C 12-Bar Blues Jam Track

This jam track is in the same format as the previous track except it is in the key of C. The previous track is the same progression except its in the key of G. Utilizing tracks in different keys allows you to work on your soloing techniques and improvisation all over the neck and gets you comfortable in various keys.

In this jam track the chords are C - F - G. The track is a very traditional standard I-IV-V 12-bar blues in the key of C. It has the most common pattern, or length of time on each chord for a 12-bar. Again, as soon as you hear this jam it should kick off in your head that this is a standard I-IV-V blues jam and that there will be many soloing options.

Like many blues jams this one starts off on the V chord. You will often hear in blues, “let’s take it from the V”, a very common way to start a blues jam. This jam features a pinky embellishment on each chord adding the 6th, another very traditional device in blues rhythm playing.

What Relates to all the chords:

-For that bluesy minor sound try C Minor Pentatonic & Blues over all the chords.

-For that sweet major sound try C Major Pentatonic over all the chords. Remember that for most major key jams you can use Major Pentatonic over all the chords. C Major Pentatonic is the same as A minor Pentatonic. C Major and A minor are relative major and minor. If you think more in terms of Minor Pentatonic or just know those scales then play A Minor Pentatonic scales, but start on and emphasize the C notes and it will be C Major Pentatonic.

-Try C Dorian over all the chords. Because we know that both major pentatonic & minor pentatonic will work we then know that the Dorian mode will also work. Remember Dorian is considered more of a minor mode but works great over major key I-IV-V blues, swing, and shuffle progressions. So try C Dorian over all the chords. C Dorian is the same as Bb major, C Dorian=Bb major. So play Bb major scales but emphasize and start on the C notes.

-Mix both C Minor Pentatonic & Blues, C Major Pentatonic, and C Dorian over all the chords.

Treat each chord like a separate event:

With this 12-bar pattern there is not as much time on each chord as some of the slower jam tracks. But there is enough time on each chord to treat each chord as a separate event if you are quick. Just time your changes over each chord and really listen to the rhythm to ensure you don’t get caught playing the wrong scale or in the wrong key over a given chord.

-Try moving Minor Pentatonic & Blues over each chord. Try C Minor Pentatonic & Blues over the C chord, try F Minor Pentatonic & Blues over the F chord, and try G Minor Pentatonic & Blues over the G chord.

-Move Major Pentatonic over each chord. Try C Major Pentatonic over the C chord, Try F Major Pentatonic over the F chord, and try G Major Pentatonic over the G chord.

-Move the Dorian mode over each chord. Because the rhythm of this jam is embellished with the 6th, Dorian is a perfect choice as that is a key interval in the mode, 1,2,b3,4,,5,6,b7. Try C Dorian (=Bb major) over the C chord, try F Dorian (=Eb major) over the F chord, and try G Dorian (=F major) over the G chord.

King Inspired B Minor Jam Track

This jam track is in the same format as the G minor blues jam track listed on page 17. However, this track has a slightly different feel and its in the key of B minor. In this track the chords are Bm7 - Em7 - G - F#7, and the turnaround is on F#7#9. This track is in the key of B minor.

Note that in this track the chords are moving by fairly slow, so it's a great jam for treating each chord as a separate event. Remember that if the chords are flying by very fast you don't have enough time to solo on each chord independently. In those cases you would be playing more of what relates to all. Also refer to the coinciding video lessons for in depth studies on jamming over this track.

What Relates to all the chords:

-For the bluesy minor sound try B Minor Pentatonic & Blues over most of the chords. So whether you are playing over the Bm7, Em7, or G chords, play B Minor Pentatonic & Blues scales all day long in this jam. But be careful around the F#7 chord as that is a V major type chord in a minor key progression. We are in a minor key jam but it has a major type V chord. The F#7 chord moves by pretty fast so if you are careful you can steer around it while using Minor Pentatonic & Blues.

The issue is that the F#7 chord is made of the notes F#, C#, E, and Bb. So the chord really wants to resolve to that Bb note and not necessarily the B note. Bm is the tonality we are playing in with B Minor Pentatonic. So just be cognizant of which notes you are landing on over the F#7 chord and try to not hang on the Bb note while on that F#7 chord, try to just roll it up a half step to B. It will resolve better on that B note. Also, be sure to try another option on just that F#7 chord as listed below.

-Try B Aeolian, (B Natural Minor), over all the chords. In minor key, a minor mode usually relates to all the chords. So we can usually play a minor mode over all the chords. Since we are in a minor key jam and when analyzing the chords the iv chord is minor, Em7, then this tells us we can play B Aeolian mode, (B Natural Minor), over all the chords. Aeolian mode intervals are 1,2,b3,4,5,b6,b7. B minor is the relative minor of D major. So, play D major scales, but to make them B Aeolian, start on and emphasize the B notes, B Aeolian = D major. Remember to keep resolving your licks to those B notes.

-Mix both B Aeolian and B Minor Pentatonic & Blues over all the chords for some killer sounds.

Treat each chord as a separate event:

In this jam the chords are slow moving with lots of time on most of the chords, so here is a great opportunity to treat each chord as a separate event.

-Over the Bm7 chord try B Minor Pentatonic & Blues, B Aeolian, B Dorian, or B minor arpeggios.

-Over the Em7 chord try E Minor Pentatonic & Blues, E Aeolian, E Dorian or E minor arpeggios.

-Over the G chord try some G major licks or a G major arpeggio.

-Over the F#7 chord try some F# major licks or a F#7 major arpeggio, or F# Mixolydian. The Mixolydian mode works awesome over dominant type chords like 7ths and 9ths. Those chords have a b7 in them and so does the Mixolydian mode - 1,2,3,4,5,6,b7. F# Mixolydian is the same as B major. So play B major scales over the F#7 chord but emphasize the F# notes for F# Mixolydian.

***Note** - remember you don't have a lot of time on the G and F#7 chords in this jam, just enough to rip a cool major lick or 7th arpeggio over each chord. Be sure to get off in time when the chords change so you don't get caught playing the wrong scale in the wrong key over the wrong chord.

Scales Defined

Learning and understanding scales is a critical element in your guitar journey. Scales are the building blocks to creating licks and the roadmap to the fretboard. Pentatonic Scales are the most common scales used in most genres of music so they are a great place to start, especially for blues and rock.

Scales are a group or collection of notes in ascending or descending order that we use in music. Scale notes are listed out in order and usually sound from low to high.

The order of the notes utilized in a scale is crucial as that order provides a measure of musical distance. The distance between notes is called an interval. How scale notes line up, or the intervals, will give the scale not only its name but also its mood or musical color. Just like certain chords have a mood to them, scales also produce a certain sound or mood.

One critical aspect of a scale is its root note. The root note is the starting note and note which all the other scale notes gravitate toward. I like to call the root note “home base”. Most other notes seem to want to resolve to the root as it’s the tonic center for the scale. Often you can determine the key of a given progression by just listening for what sounds like home base, what all the chords are pulling toward.

When learning scales, always make mental notes as to where the root notes are in that scale. In all my educational materials as well as in this eBook the root notes are illustrated with black ovals. It’s critical to know your root note locations.

The successive notes in a scale are divided by steps, or tones. A half step is also called a semi-tone and is one fret on the guitar. A whole step is also called a whole tone and is two frets. A minor third is three frets and a major third is four frets.

The table below illustrates some common scales and their intervals. Scales listed below in red text are the modes of the major scale. When learning scales also learn their application and how to play them in all keys.

Major Scale	1	2	3	4	5	6	7
Natural Minor Scale	1	2	b3	4	5	b6	b7
Minor Pentatonic Scale	1		b3	4	5		b7
Blues Scale	1		b3	4	b5	5	b7
Major Pentatonic Scale	1	2	3		5	6	
Major Pentatonic Sus4 Scale	1	2	3	4	5	6	
Ionian Mode (Major Scale)	1	2	3	4	5	6	7
Dorian Mode	1	2	b3	4	5	6	b7
Phrygian Mode	1	b2	b3	4	5	b6	b7
Lydian Mode	1	2	3	#4	5	6	7
Mixolydian Mode	1	2	3	4	5	6	b7
Aeolian Mode	1	2	b3	4	5	b6	b7
Locrian Mode	1	b2	b3	4	b5	b6	b7
Harmonic Minor Scale	1	2	b3	4	5	b6	7

Minor Pentatonic - The Basic Box Shape

Pentatonic scales are the most commonly used scales in most genres of music. You will want to get very comfortable with them. Often they are the first scales students learn on their lead guitar journey.

Penta is Latin for five. Like a penta-gram has five sides and a pentagon has five sides, pentatonic scales are constructed from five notes.

The minor pentatonic scale is constructed from five notes of the natural minor scale. The intervals in minor pentatonic are root or 1, b3rd, 4th, 5th, and b7th.

The scale illustrated on the right is the most common basic “box” position. This scale has its low root played with the first finger on the low E string. The root notes are illustrated with black ovals and the numbers inside the circles indicate the fingering to be utilized when playing this scale. At first try utilizing one finger per fret.

We are going to build upon this scale in coming lessons. Eventually you will need to learn this scale in all positions all over the neck, and in all keys.

Start with this basic box, then on to the Expanded I, and eventually all five box shapes as illustrated in the coming pages of this eBook.

Practice the scale utilizing the fingerings illustrated. Sound each note clean, with no string buzzes or overtones. As you move through the scale make a mental note of when you hit the three root notes.

The key signature is determined by which root note is played. If you play this scale starting at the third fret on the low E string it is a G minor pentatonic scale consisting of notes G, Bb, C, D, and F.

If you were to play this scale starting on the 8th fret, it would be a C minor pentatonic scale consisting of notes C, Eb, F, G, and Bb.

Much like moveable bar chords this scale can be moved up and down the guitar neck and the root note will determine the key you are playing. Practice the scale in all keys and apply it over the jam tracks as per the video lessons and jam track application suggestions.

This scale will form the building block of many concepts in the coming lessons. You want to be very familiar with this scale pattern, but do not rely on it exclusively.

Next we will be expanding this scale across the fretboard. This will produce a more fluid sounding scale that you can move laterally across the neck combining multiple box positions. Get ready to rock!

Minor Pentatonic

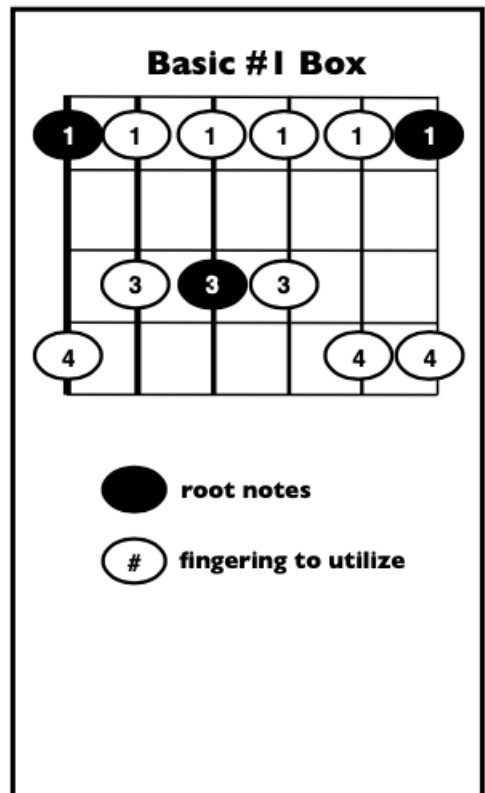

String Bending in Minor Pentatonic

Bending strings is one of the most expressive things you can do on the guitar. You will want to get very proficient and accurate with string bending, it's an art.

When bending strings, it is imperative that you are bending notes in pitch to the proper target note. You don't want to over bend or under bend notes, as they will then sound sharp or flat. Practice bending strings and then check the pitch by sounding the note you are attempting to bend to, your target note. This is a good self-check to ensure you are bending in pitch.

You can also practice string bending in pitch by plugging into an electronic tuner that has a needle and watching the needle as you bend a note and ultimately see it hit pitch. Keep doing it over and over until you feel the bend string tension-wise, as well as hear the bend in pitch match to the target note.

Play the box pattern scale illustrated on the right with a fifth fret low-E string root. That root note would make this an A minor pentatonic scale. Once you learn the string bends listed below, practice them using different shapes and in all keys. For now try the bends in A minor pentatonic using the basic box shape.

1. b3rd to major 3rd bend. Bend the b3rd or C note a quarter to a half step to the major 3rd. This is a very cool bend as the b3rd is a very ambiguous note in this scale. It sometimes will sound great as the b3rd but also as a major 3rd. This note has some play in it and you don't have to be exact with the bend. Play with it and you will soon be utilizing this bend all the time.

2. Bend the 4th a half step to the blue note. Bend the D note 7th fret G string up one half step to the Eb note. This is a very popular blues bend.

3. Bend the 4th degree a whole step to the fifth. Bend the D note 7th fret G-string up one whole step to the E note. The 4th or D note can be bent either a whole or a half step.

4. Bend the b7th a whole step up to the root. Bend the G note 8th fret B string up one whole step to the A root note. You can also bend the same note an octave lower at the G note at the 5th fret on the D string up one whole step.

5. Unison bend. Use your 4th finger to bend the G note 8th fret B string a whole step to an A note while playing the A note 5th fret high E string with your 1st finger.

6. Unison bend. Use your 3rd finger to bend the D note 7th fret G string a whole step to an E note while playing the E note 5th fret B string with your 1st finger.

7. Bend the b3rd a full step to the 4th. Bend the C note 8th fret high E string one whole step to the D note.

8. Double stop bend. Bend two strings a half step each with your 3rd finger by barring across the 7th fret with one finger. Bend the D note 7th fret G string one half step while also bending the F# note 7th fret B string one half step.

8. Double stop bend. Use your 3rd finger to bend the D note 7th fret G string a whole step while playing the G note on the B string 8th fret with your 4th finger.

Experiment and get creative with these string bending ideas. Remember to keep checking your bends to ensure you are bending in pitch.

Minor Pentatonic - The Five Box Shapes

The five minor pentatonic box shapes illustrated below cover the entire guitar neck. These are “must-know” scales, especially for blues and rock. Take your time learning them, chip away a little each day. As you move through each scale make a mental note of when you pass through a root note, which are illustrated in black.

These five positions are the architecture to build endless licks and runs. They also connect into longer expanded scales that you will learn in the coming pages. To avoid getting stuck in one position be sure to learn ALL the positions and practice them in different keys over the included jam tracks.

These scale shapes are moveable and the key is determined by the low root note. For example, if you want to solo with Box #1 in G minor pentatonic use your first finger starting at the third fret on the low E-string and play the shape. Third fret low-E string is an G note. That makes the scale an G minor pentatonic scale with the notes G, Bb, C, D, and F.

To try another pentatonic box in G minor play box #3 using your 3rd finger at the 10th fret A-string. Fret ten on the A-string is a G note. You are playing the same five notes as in the above example, G, Bb, C, D, and F, just in a different position on the guitar neck.

Along with memorizing the scale shapes it is also critical to know what notes you are playing and how to apply these scales. Too often, guitarists memorize only shapes. Don't just learn scale shapes, take the time to also learn the notes and how to musically apply the scale, in the end it will make you a better musician.

Another critical element when learning scales is to not only memorize the scale but also learn it's application. Learn how to apply it in a musical context - over what chords, in what key. Practice these scales as per the video lessons and use jam tracks in various keys.

The diagram illustrates five minor pentatonic box shapes on a guitar fretboard, labeled #1 Box through #5 Box. Each shape is shown on a six-string fretboard with frets 1-5 indicated. Fingerings are shown in circles, and root notes are shown in black circles. A legend at the bottom right defines the symbols: a black circle for 'root notes' and a circle with a '#' for 'fingering to utilize'.

- #1 Box:** Root note on the 3rd fret of the low E-string. Fingering: 1 (black), 1, 1, 1, 1, 1 (black) on the top string; 3, 3 (black), 3 on the second string; 4, 4 on the fourth string; 4, 4 on the fifth string.
- #2 Box:** Root note on the 5th fret of the low E-string. Fingering: 1, 1 (black), 1 on the top string; 2 on the second string; 1, 1 on the third string; 3 on the fourth string; 4, 4, 4 on the fifth string; 3 (black), 3 on the sixth string.
- #3 Box:** Root note on the 7th fret of the low E-string. Fingering: 1 on the top string; 1, 1, 1 on the second string; 1 (black), 1 on the third string; 3, 3 (black), 3 on the fourth string; 4 on the fifth string; 3 on the sixth string.
- #4 Box:** Root note on the 9th fret of the low E-string. Fingering: 1, 1 (black), 1, 1 on the top string; 1 on the second string; 2 on the third string; 3, 3 (black) on the fourth string; 4, 4 on the fifth string; 4, 4 on the sixth string.
- #5 Box:** Root note on the 12th fret of the low E-string. Fingering: 1, 1 (black) on the top string; 2, 2 on the second string; 1 on the third string; 1 (black) on the fourth string; 2, 2 on the fifth string; 4, 4, 4, 4, 4, 4 (black) on the sixth string.

Minor Pentatonic - The Expanded Shapes

Let's build on the minor pentatonic scales that you learned in the previous lesson. We will expand the scale two frets in each direction combining three box shapes to double the playing area. These expanded scales will get you playing ACROSS the neck and eliminate the "stuck in the box" scenario.

We are still going to play the same five-note pentatonic scale but these expanded scale produce a more fluid sound as opposed to staying in just one vertical box. You certainly want to have all the box patterns in your playing arsenal, but these expanded scales open the pathways and lead guitar avenues. You will utilize these expanded scales all the time, they are invaluable.

Illustrated below, are three box patterns encapsulated within each of the longer shapes. The expanded shapes are stretched two frets in each direction combining three adjacent boxes. The expanded I scale combines boxes 5, 1, and 2 while the expanded II scale combines boxes 3, 4, and 5.

These expanded pentatonic scales double the fret span of the single box patterns. Practice these expanded scales in different keys and add them to your playing arsenal.

Just like the box patterns these expanded scales are moveable and the root note determines the key. Same principle applies to finding them in the proper key as with the individual box shapes.

To play these expanded scales in G minor first find the G notes.

To play the expanded I scale in G minor, start with your third finger on the 3rd fret of the low E-string and play the shape. Third fret low E-string is a G note.

To play the expanded II scale in G minor, start with your third finger on the 10th fret of the A-string and play the shape. Tenth fret A-string is a G note.

To locate these scales fast, find the low root note. The expanded I uses 3rd finger root on the low E-string and the expanded II uses 3rd finger root on the A-string.

Find the root notes and blast away from there!

Practice in all keys and over the included jam tracks. Put on the tracks and just get lost in them!

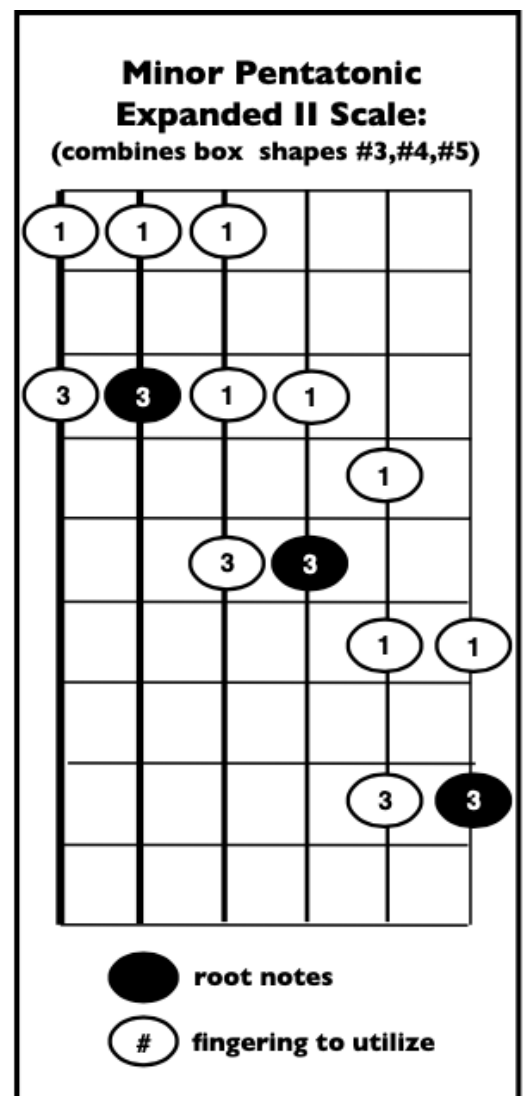
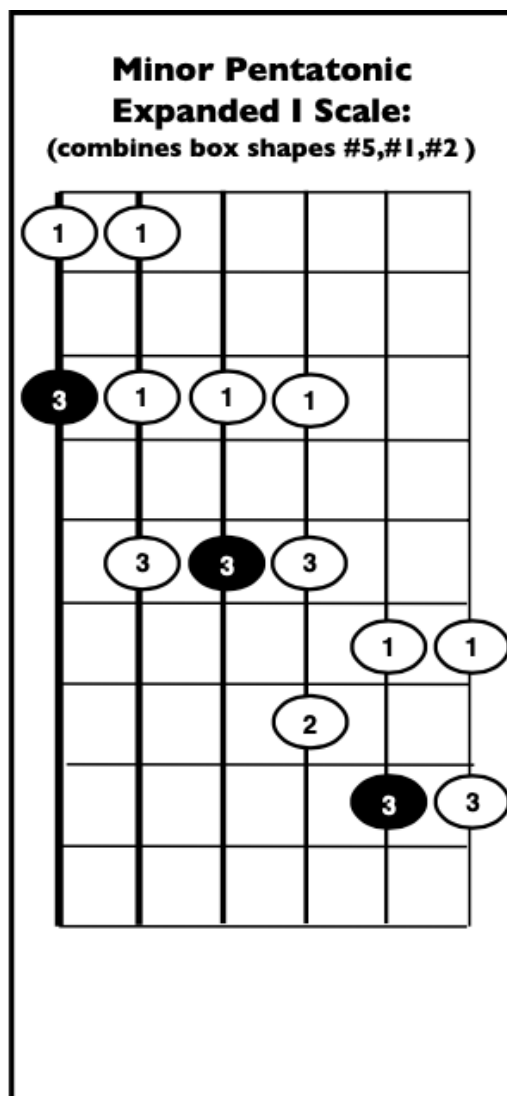

Minor Pentatonic & Blues- The Five Box Shapes

Now we will add one note to the minor pentatonic scale and turn it into the six-note blues scale. Pentatonic & Blues scales are the most commonly used scales in most genres of music.

We can add the flat 5, (b5), or blue note to the pentatonic scale, making it a six-note scale called the Blues Scale. That b5, or blue note, adds a lot of tension and color to the scale. These are “must-know” scales especially for blues and rock so be sure to memorize them and add them to your soloing repertoire.

Most of the time when soloing with minor pentatonic scales you can also use the blues scale. To be safe, at first, use the blue note more in passing for color, don't hang on it too long. Hanging on that flat five too long can sound a bit dissonant. It's a great note though, so experiment with it and let your ear guide you.

The five box shapes illustrated below cover the entire neck. These five positions are the architecture to build licks and runs as well as to connect into longer expanded scales. To work freely across the entire neck you will want to memorize all five positions as well as the two expanded scales illustrated on the next page.

These scale shapes are moveable. The key is determined by the root notes illustrated in black. If you want to solo in G minor pentatonic play box #1 using your first finger starting at the 3rd fret on the low E-string and play the shape from there. Third fret low-E string is a G note. That makes the scale a G minor pentatonic & blues scale consisting of the notes G, Bb, C, Db, D, and F.

Remember that along with memorizing the scale shapes it is also critical to know what notes you are playing. Too often, guitarists memorize only shapes and forget what notes they are actually playing. Don't just learn scale shapes, take the time to also learn the notes.

To avoid getting stuck in one position be sure to learn ALL the positions and practice them in different keys. Use the blue notes in passing, resolve often to the root notes, and land on strong chord tones.

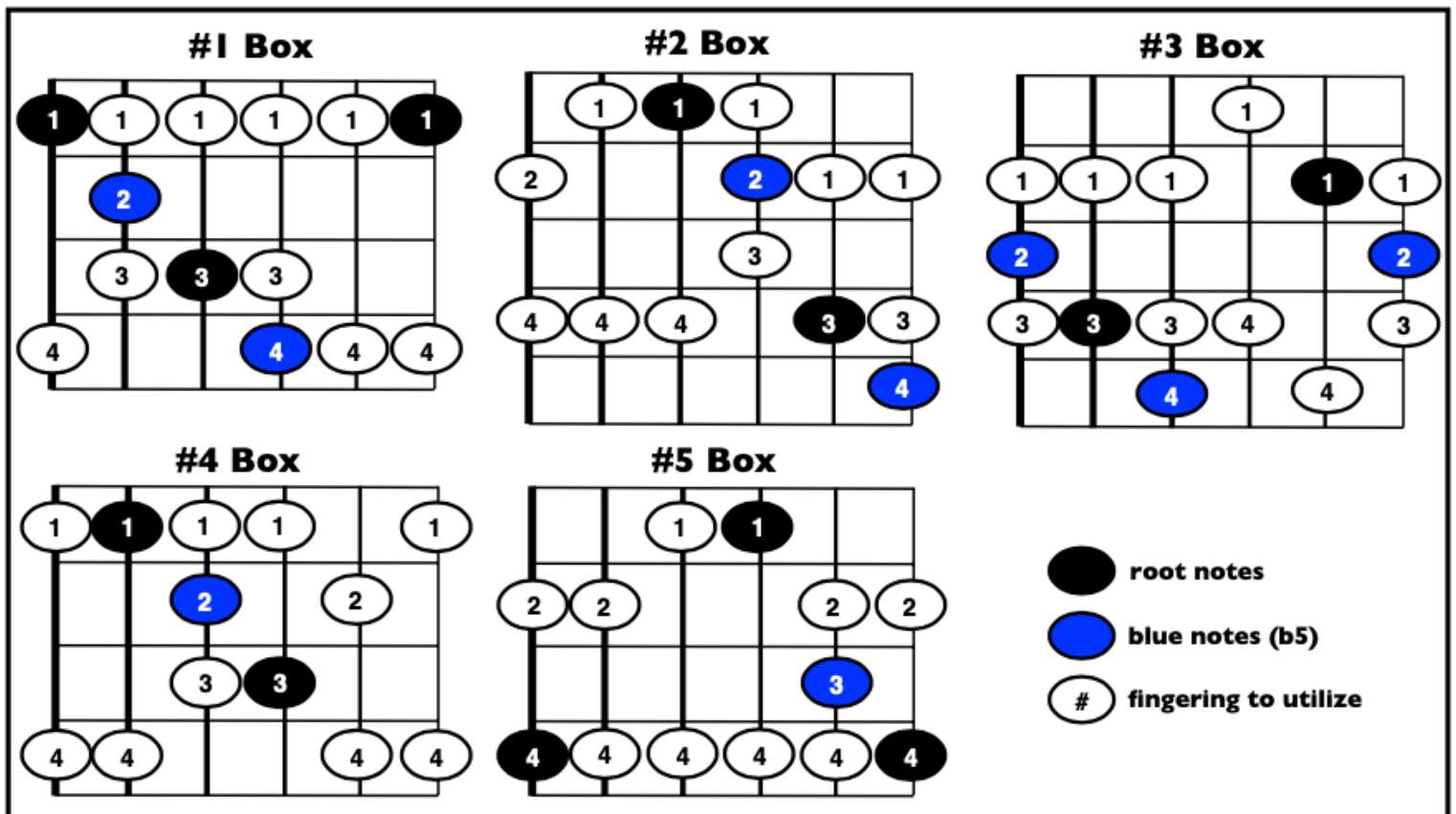

Minor Pentatonic & Blues- The Expanded Scales

Let's build on the minor pentatonic & blues scale that you learned in the previous lesson. Now we will expand the scale two frets in each direction thus combining three box shapes and doubling the playing area. These expanded scales will get you playing ACROSS the neck and eliminate being "stuck in the box".

We are still going to play the same six-note scale. However, the expanded scales exude a much more fluid sound that set up additional lick opportunities. You certainly want to have all the box patterns within your grasp, but these expanded scales really open the pathways and guitar avenues. You will utilize these expanded scales all the time, they are invaluable.

Illustrated below you can see part of three box patterns encapsulated within each longer shape. The shape is expanded two frets in each direction combining three adjacent boxes. The expanded I scale combines boxes 5, 1, and 2 while the expanded II scale combines boxes 3, 4, and 5.

These expanded blues scales double the fret span of the box patterns. Practice these in different keys over the jam tracks and add them to your practice regimen.

Like the box patterns these expanded scales are moveable with the root note determining the key.

Same principle applies to finding the expanded scales in the proper key. To play these scales in G minor, first find the G notes.

To play the expanded I scale in the key of G minor, start with your third finger on the 3rd fret of the low E-string and play the shape. Third fret low E-string is a G note.

To play the expanded II scale in G minor, start with your third finger on the 10th fret of the A-string and play the shape. Fret ten on the A-string is a G note.

To locate these scales fast find the low root note. The expanded I uses 3rd finger root on the low E-string and the expanded II uses 3rd finger root on the A-string.

Find the root notes and blast away from there - enjoy!

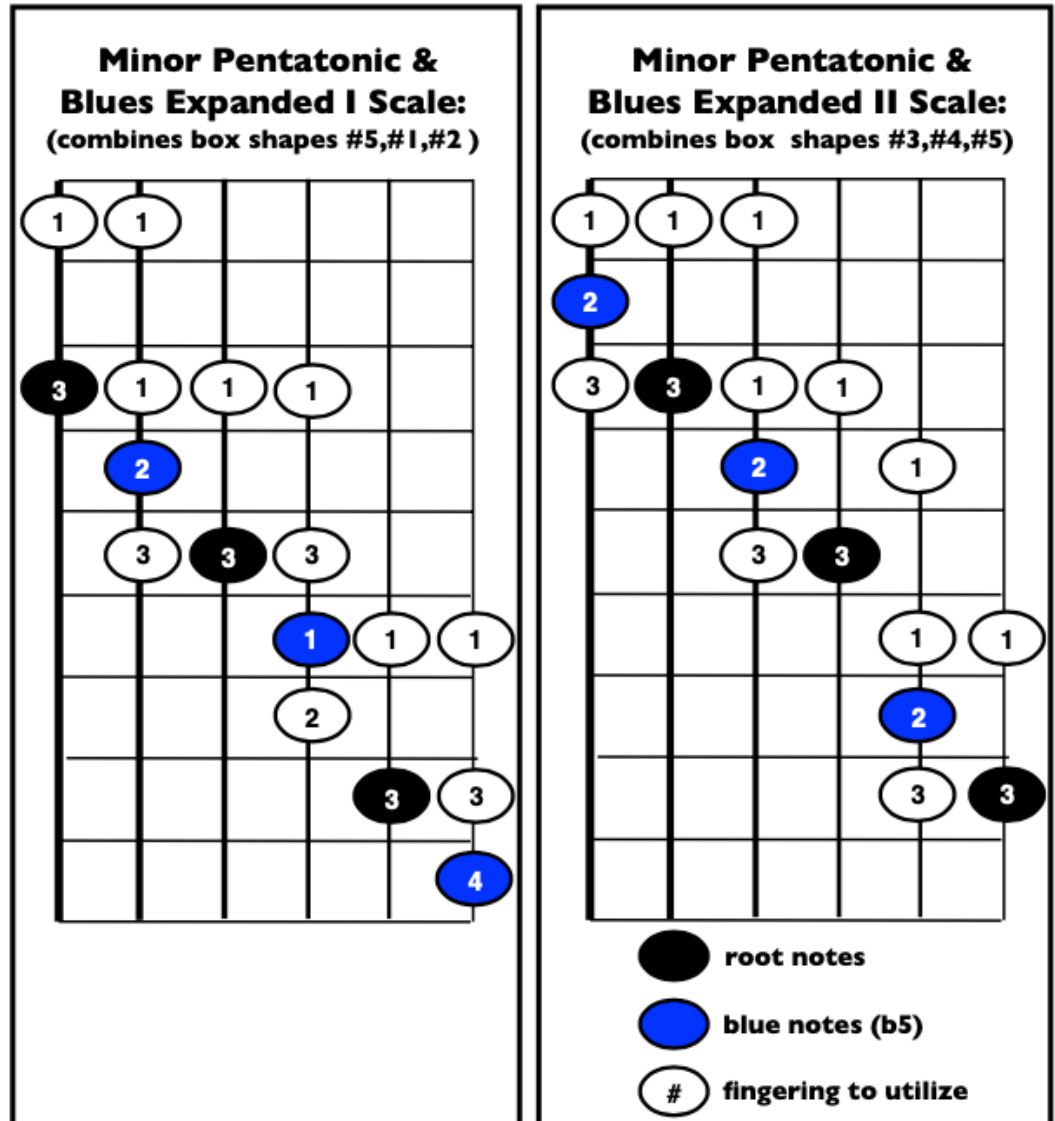

The Major Pentatonic Scale

The major pentatonic scale is a five-note scale consisting of five notes from the major scale. The intervals are 1, 2, 3, 5, 6. You do not play the 4th and 7th degrees of the major scale. This incredibly useful scale produces a sweet, happy, major sound and is utilized often in blues, rock, and other musical genres.

Major pentatonic often works over all the chords in major key when playing what “relates to all”. Also, utilize major pentatonic over most major type chords when treating each chord as a “separate event”.

You can locate major pentatonic scales all over the neck by going through the minor pentatonics. You won't have to memorize a whole new batch of scale shapes for major pentatonic. We will use the concept of major and relative minor to easily tackle major pentatonic scales across the neck.

For every major key there is a relative minor key with exactly the same notes. We will use this to help find where these major pentatonic scales “live” on the fretboard. Minor pentatonic lives a minor 3rd, or three frets away, below the major pentatonic.

Illustrated below is the “basic box shape” D major pentatonic. Find it easily by using your fourth finger on the root note low E-string. It's relative minor, B minor pentatonic is illustrated on the right. D major pentatonic scales can also be viewed as B minor pentatonic scales. Both scales consist of the same notes D, E, F#, A, and B. There are lots of ways to look at these, personally I think of pentatonics more in terms of minor.

The starting and emphasis notes determine which scale you will be playing. D major pentatonic and B minor pentatonic consist of the same notes, just different starting and emphasis notes. It all comes down to what notes you are emphasizing, emphasis is critical.

Play both scales starting and ending with the roots. Listen how the major pentatonic is sweet and happy sounding when starting on and emphasizing the D notes. Play the same shape but start and end on the B notes and you get the darker, bluesy, minor sound. Same notes, just different start and emphasis points, and you have two very different sounding scales.

One scale gives you the sweet, bright, major sound while the other gives you the dark, bluesy, minor sound. Try playing minor pentatonic over minor chords and major pentatonic over major chords within the same jam track. Be sure to change scales as the chords change and listen for the sound differences between the major and minor, get lost in the fun.

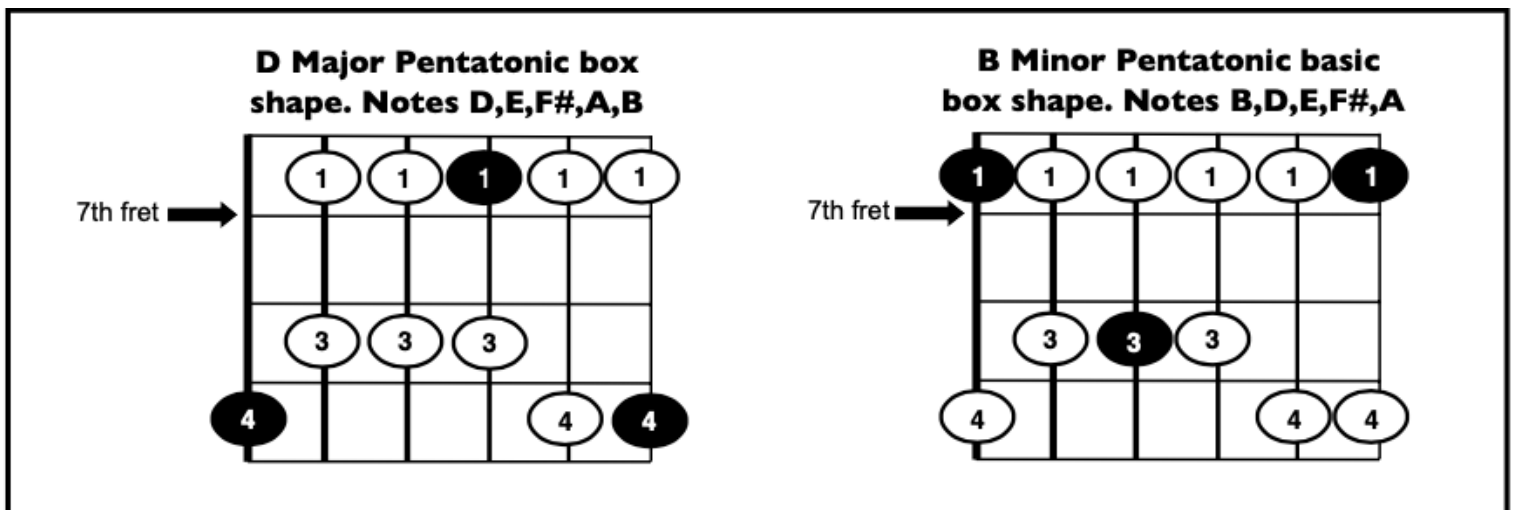

The Major Pentatonic Scale - Key Points

The major pentatonic scale is constructed from five notes of the major scale. This is similar to how the minor pentatonic scale is constructed from five notes of the natural minor scale, (see below table).

1	2	3	4	5	6	7	= major scale
1	2	3		5	6		= major pentatonic scale
1	2	b3	4	5	b6	b7	= natural minor scale
1		b3	4	5		b7	= minor pentatonic scale

Remember that you can find all the major pentatonics by going through the relative minor pentatonic scales. Just flip the minor pentatonic shapes to their relative major pentatonic and change emphasis notes. Here are all the major keys and their corresponding relative minors:

A major = F# minor	Bb major = G minor	B major = G# minor
C major = A minor	C# major = Bb minor	D major = B minor
Eb major = C minor	E major = C# minor	F major = D minor
F# major = Eb minor	G major = E minor	G# major = F minor

For that sweet major pentatonic sound utilize all of your minor pentatonic scales, but emphasize the root major. For example, when playing in D major pentatonic think of the relative minor B minor pentatonic. Just start and emphasize on the D notes, not the B notes, to sound major.

The blue note does not always apply to major pentatonic and, at times, can sound sour. Experiment with it and see how it sounds to your ears.

The major pentatonic lives three frets ahead of the minor pentatonic. For example, if you want to play in D major pentatonic put your pinky finger on the D note 10th fret low E-string. Using one finger per fret, the relative minor will always be three frets back.

Your first finger will always fall on the relative minor. In this case, the B note at the 7th fret of the low E-string. Find the relative minor of any major key using this device.

There is not much room for error when soloing in major key as sour notes can really stick out. You also can't slur passing tones like when using minor pentatonic.

Be careful with your note choices and let your ear help guide you. Practice these scales in all keys and listen for the sound differences between minor and major. Its all about the sounds and moods that these scales produce - stay creative and keep on rocking!

KEY POINTS:

For every major key there is a relative minor key with exactly the same notes.

When soloing in major key use major pentatonic over all the chords when playing what “relates to all”. Also use it over any major type chord when treating each chord as a “separate event”.

Find major pentatonic scales by going through the relative minor pentatonic scales. Memorize majors and their corresponding relative minors.

The Major Scale

All music theory compares back to the major scale. You are probably familiar with the sound of the major scale – do, re, mi, fa, so, la, ti, do. We all sang that song endless times in elementary school. There are many different fingerings and ways to play major scales all over the guitar neck.

Below is a system of six major scales. With all six memorized, you can utilize the entire guitar neck. The scales overlap each other, and on the next page you will learn to link these scales together.

The major scale is constructed from seven notes built from the scale degrees of 1, 2, 3, 4, 5, 6, 7. Memorize the scales one at a time. Take your time learning them, perhaps chipping away a little each day. As you move through each scale make a mental note of when you hit the root notes, illustrated in black.

The key signature for each scale is determined by its root note. First learn the scales below in the key of G major. The scales line up nicely in G, so G major is a good place to start. To play the #1 scale in G major, put your 2nd finger on the 3rd fret on the low E string, G note, and play the shape. You will now be playing a G major scale which consists of the seven notes G, A, B, C, D, E, and F#.

To play scale #2 in G, put your first finger on the G note on the low E string at the 3rd fret and play the shape. These scales can be moved up and down the guitar neck and should be practiced in all keys. Know your major scales cold and then you will also know all the modes of the major scale. More on that to come later in this eBook.

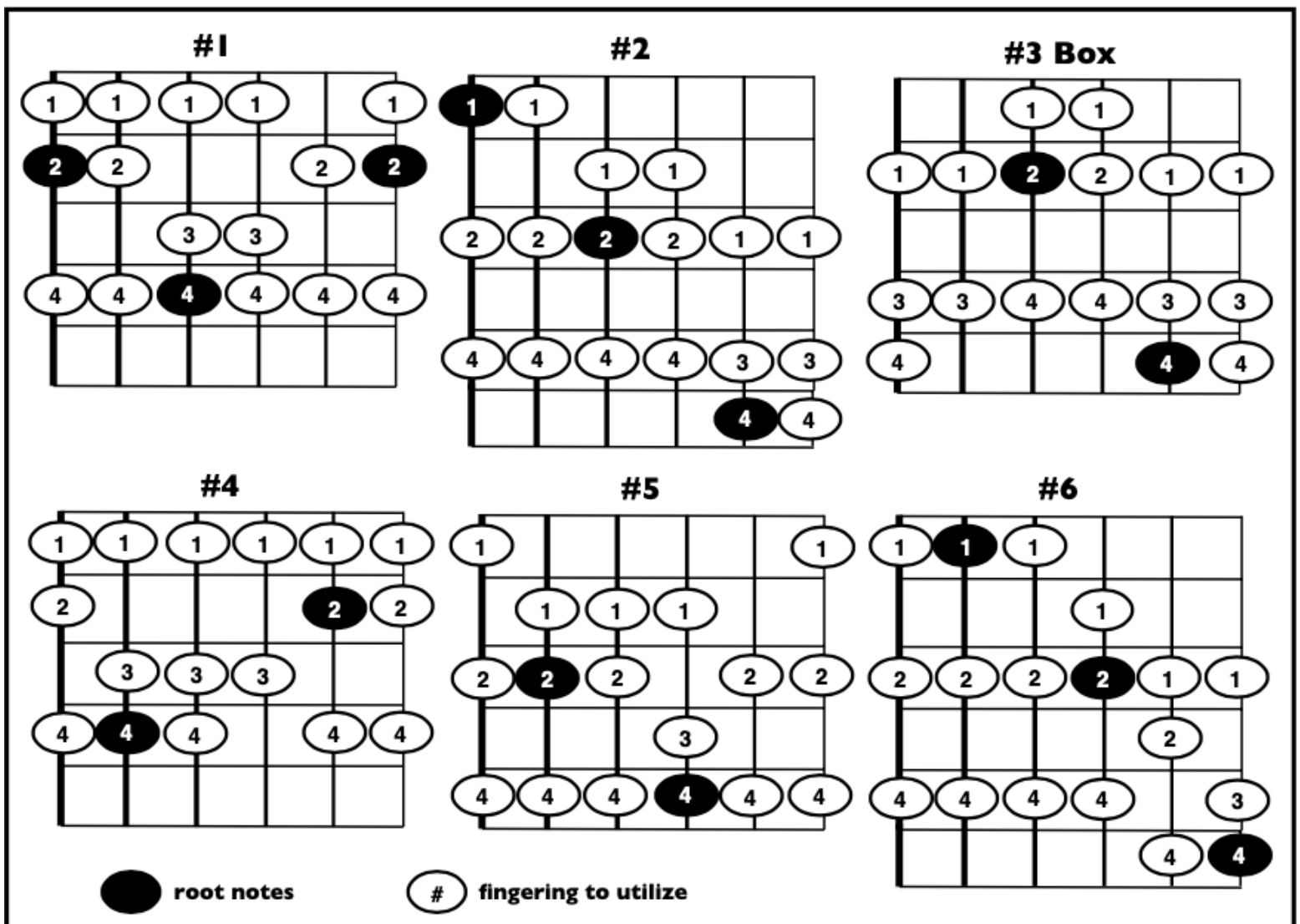

Major Scale Links

Now that you know six major scales from the previous lesson, let's link them together and play them across the neck. These links help view the entire neck as one big scale.

Below are two examples of three octave major scale links that combine three shapes. These are incredibly useful and are easy to play. Both utilize easy to remember repeated fingerings. These scale links help you to practice lateral playing across the neck. Shift with your first finger for both these examples when you get to the D and the B strings. Shift up a whole step or two frets, with the first finger for the 1-1 finger combination. Practice these links in all keys, they are super useful.

Link 1 utilizes 1-2-4 fingering to play the entire scale link. Shift up with the first finger as indicated. Link 2 utilizes 1-3-4 fingering to play the entire scale link. Again, shift up with the first finger as indicated. Be sure to always make mental notes when passing through root notes. Just like the other scales we have discussed in this eBook, these scale links are moveable with the root note determining the key.

To locate these scales fast, first find the low root note. To play these links in G major, first find the G notes. To play the Link 1 in G major, start with your 2nd finger on the 3rd fret of the low E-string and play the shape. Third fret low E-string is a G note.

To play Link 2 in G major, start with your 4th finger on the 15th fret of the low E-string and play the shape. The 15th fret low E-string is a G note.

Find the root notes and blast away from there!

If you have a minor key jam, for example, let's say a jam in the key of A minor, you can still utilize these major scales in the parent scale of C major. C major's relative minor is A minor. Use major and relative minor as discussed in previous lessons.

Convert both of these shapes back to the parent scale of C major and start on and emphasize the A notes for A Aeolian, (A natural minor). Remember, its all about emphasis and mood.

More to come on that device in the "Modes" lessons coming up later in this eBook. Rock on!

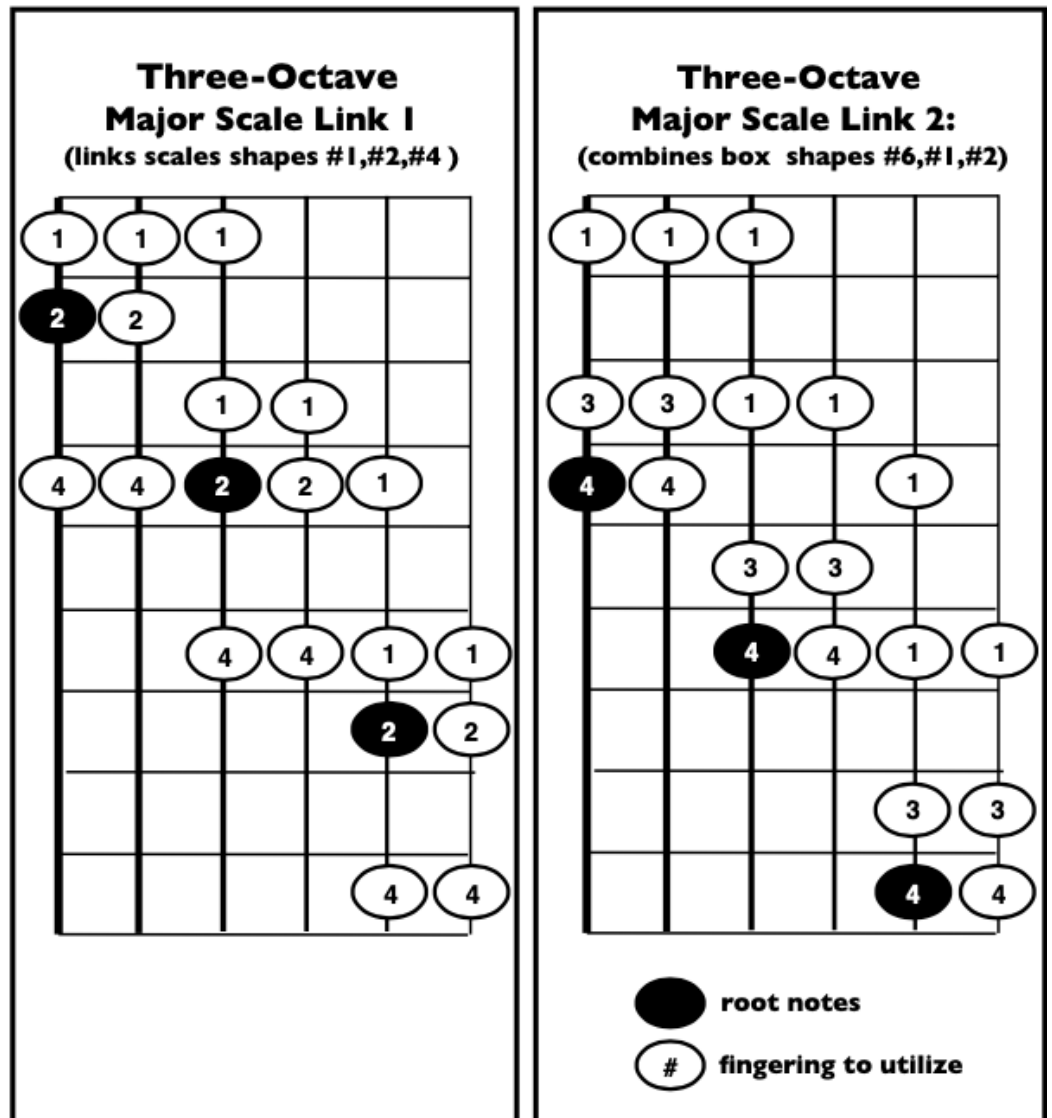

The Modes Of The Major Scale - Overview

There are seven modes of the major scale and each one has its own “mood”, or distinct sound. Knowing the modes gives you the ability to create various moods and textures. They also open the door to additional soloing options.

Modal playing is often thought as an abstract and mysterious entity, one that requires a black belt in music theory to understand. That is not true. You can be playing modally with just a little coaching and practice.

Utilizing the modes will generate interval structures that are different than the major scale and therefore produce unique sound qualities.

Each mode has its own unique sound or “mood” due to its unique interval structure. Some modes are more major sounding and some more minor sounding. My modal methodology requires that you first know your major scales. We will get to all seven modes through the major scales.

Think of the modes as being variations of the major scale. All you will be doing is starting on and emphasizing a note in the major scale other than the root note.

There are seven notes in the major scale and each one corresponds with a different mode. So there are seven modes of the major scale and they always appear in this order: Ionian, Dorian, Phrygian, Lydian, Mixolydian, Aeolian, and Locrian. Memorize the mode names and their order. The order of the modes is very important.

Learn the major scales and how to link them as they are diagrammed out in this eBook. Once you know your major scales you don't have to learn a whole new set of scales for each mode. You will then know all the modes of the major scale because you will be using those same major scale shapes to play all the modes.

You will be starting on any of the six shapes on a note other than its root. Keep in mind it's all about the mood or distinct sound of each mode - that's the key, it's all about the sounds.

Besides knowing your major scale, (Ionian Mode), get proficient with the Aeolian Mode, Dorian Mode, Lydian, and then Mixolydian mode. These modes are used most often in blues and rock and we will focus on them in the coming pages of this eBook.

THE SEVEN MODES OF THE MAJOR SCALE

1st mode - **Ionian** (same as the Major scale)

2nd mode – **Dorian** (same as Aeolian but with a raised 6th)

3rd mode - **Phrygian** (same as Aeolian but with a b2nd)

4th mode – **Lydian** (same as Ionian but with a #4th)

5th mode – **Mixolydian** (same as Ionian but with a b7th)

6th mode – **Aeolian** (same as Natural Minor)

7th mode – **Locrian** (dissonant, same as Phrygian with a b5th)

KEY POINTS:

Think of the Modes simply as variations of the major scale.

Anytime you play a major scale and start on and emphasize a note other than the root, you are playing in the modes.

Each mode has its own unique sound or “mood” due to the unique interval structure of each mode.

Some modes are more major sounding and some more minor sounding.

The Modes Of The Major Scale - Application 1

The key to understanding the modes is to look at the interval structure that defines each mode and then match them with corresponding chords and progressions. Let's discuss each mode and how to apply them.

With any mode or scale it's not enough just to know the scale, you also have to know how to use it and apply it in a musical situation.

Many of the modes are very similar in their structure. Some have just one interval difference. But these slight differences create unique moods and textures. Each mode has its' own unique mood and tone.

The table below shows each mode and its interval structure. The last column denotes which modes are considered major modes and which are considered minor modes.

Memorize which are the major modes, Ionian, Lydian, and Mixolydian, and which are the minor modes, Dorian, Phrygian, Aeolian, and Locrian. Knowing this will help guide you to utilizing the correct mode over a given chord or progression.

<u>#mode</u>	<u>name</u>	<u>intervals</u>	<u>type of mode</u>
1	Ionian	1,2,3,4,5,6,7	major mode
2	Dorian	1,2,b3,4,5,6,b7	minor mode*
3	Phrygian	1,b2,b3,4,5,b6,b7	minor mode
4	Lydian	1,2,3,#4,5,6,7	major mode
5	Mixolydian	1,2,3,4,5,6,b7	major mode
6	Aeolian	1,2,b3,4,5,b6,b7	minor mode
7	Locrian	1,b2,b3,4,b5,b6,b7	minor mode

*Dorian is considered a minor mode because it has strong elements of minor (b3, b7), along with major (2,6). However, it can be played in some major key progressions.

Dorian works great over all the chords in major key I-IV-V shuffle, blues, or swing type progressions. For those type progressions you can also use minor pentatonic for that minor bluesy sound, major pentatonic for that sweet major sound, or combine elements of both for the Dorian sound.

Phrygian can also be used in some major key progressions that have a b2 chord. So, there is lots of room for creativity with the modes.

Like with many lead guitar avenues, you have to use your discretion and find what sounds best to your ears. Experiment and be creative when utilizing the modes and practice over the included jam tracks. Listen for which modes sound best to your ears and get creative with them!

KEY POINTS:

With any mode or scale it's not enough just to know the scale shape, you also have to know how to use it and apply it in a musical situation.

Memorize which are the major modes - Ionian, Lydian, and Mixolydian, and which are the minor modes - Dorian, Aeolian, Phrygian, and Locrian.

Each mode has its own unique mood and tone.

The Modes Of The Major Scale - Application 2

KEY POINTS TO APPLYING THE MODES:

1. **Understand your choices when soloing and improvising.** You can solo over the entire chord progression with what “*relates to all*”, or play over each chord independently, treating each chord as a “*separate event*”.

2. **Know and analyze the chords you are playing over.** The chords provide the complete roadmap to what you can utilize for soloing and improvisation. Just knowing the key signature is not enough. Know what chords are in the progression, and then analyze them to determine what scales, modes, and landing notes to utilize.

The “ACE” principle for modal playing:

Memorize these three steps for utilizing the modes, (the “ACE” principle):

1. **ANALYZE** the chords and/or the progression to get the roadmap for which modes you can utilize.
2. Once you determine which mode or modes to use, **CONVERT** that mode back to its mother or parent major key.
3. Play the mode using the parent major scale patterns but shift to and **EMPHASIZE** the root of the mode.

This is a very systematic and methodical approach to analyzing chords for determining soloing options. Over time your ear will take you to the right notes and this whole process will be more organic. However, at the start, there is value in analyzing chords and progressions while honing your skills to a sharp edge.

The above three steps are absolutely critical to your success playing in the modes. This will take a good amount of practice. So chip away a little each day and you will get it rocking very soon. Remember you are creating a mood - feel it!

KEY PRACTICE: At first try playing a mode over the whole progression or what relates to all the chords of a jam track.

Eventually you will want to try and treat each chord as a separate event and play a different mode over each chord. Get creative and give it a try.

Take your time, don't overwhelm yourself, and practice utilizing the jam tracks. Really hone in and listen for the chord changes and the moods you create with the different modes.

KEY POINTS:

Understand your options when soloing and improvising. Know and analyze the chords you are playing over.

To apply the modes just remember “ACE” – Analyze, Convert, Emphasize.

Remember that it's all about MOOD and EMPHASIS when playing in the modes.

The Modes Of The Major Scale - Aeolian

The Aeolian Mode is a seven-note scale often used in blues, rock, jazz, and many other musical genres. It is also called Natural Minor or Pure Minor. **Aeolian is considered a minor mode and is always the 6th mode in any major key.**

Aeolian produces a sad, dark, and mournful sound that is different than minor pentatonic and Dorian. It adds melodic half steps and more lick and string bending avenues. The scale degrees are 1, 2, b3, 4, 5, b6, and b7.

Play this mode over minor chords when treating each chord as a “*separate event*”. Also utilize Aeolian over ALL the chords in a minor key jam **UNLESS** the IV chord is major or the ii chord is minor.

If you want to play G Aeolian first utilize the “ACE” principle as taught in the previous lesson. Aeolian is the 6th mode. To play in G Aeolian ask yourself what major scale’s sixth note is a G? The answer is Bb. The sixth note of a Bb major scale is a G note.

To play in G Aeolian start on the sixth note in a Bb major scale and play from the G note to the G note and you have G Aeolian. As you can see below, Bb major and G Aeolian are both constructed from the same notes.

G Aeolian = G, A, Bb, C, D, Eb, F
Bb Major = Bb, C, D, Eb, F, G, A
major and relative minor

Remember, it’s all about MOOD and EMPHASIS when playing in the modes. Depending on the note you start on and emphasize, gives you the different moods and textures of each mode.

Below are two common shapes for Aeolian. One has the low root note on the low E-string and the other has the low root on the A-string. Find these patterns fast by using your first finger on the low root. Start with these, but learn all the shapes to play Aeolian across the whole neck as per the major scale lessons in this eBook.

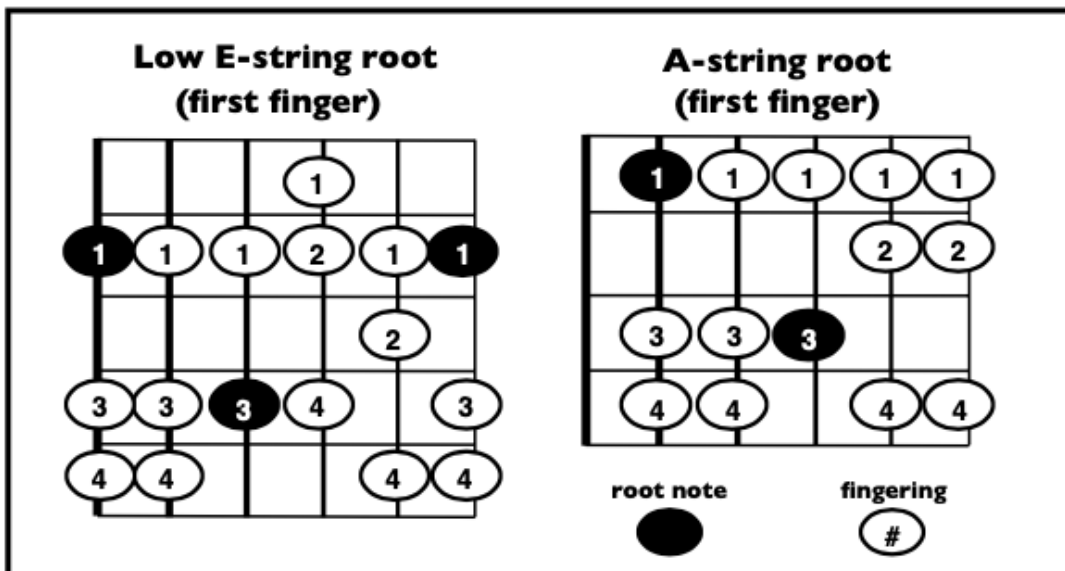

KEY POINTS:

Aeolian is always the 6th mode of any major key.

Starting on and emphasizing the 6th note of any major scale produces the Aeolian Mode.

Aeolian is also called Natural Minor or Pure Minor.

Remember, it’s all about MOOD and EMPHASIS when playing in the modes

The Modes Of The Major Scale - Lydian

The Lydian Mode is a seven-note scale often used in jazz and rock. **Lydian is a major mode and is always the 4th mode in any major key.**

Lydian is very similar to a major scale, (Ionian Mode), except it has a #4. This one alteration gives the mode a very pretty, emotive mood, almost mesmerizing. The Lydian mode scale degrees are 1, 2, 3, #4, 5, 6, and 7.

Lydian is not as commonly utilized as Ionian, but it brings a hip tension with that sharp fourth interval. Simply raise the 4th degree of any major scale a half step, and you have Lydian.

Play this mode over maj7, maj9, maj6, and maj6/9 chords when treating each chord as a "separate event". Also try it over Lydian modal chord progressions, power chords and major triads. Lydian also sounds great over rock ballads.

Lydian always is the 4th mode. To play in E Lydian ask yourself what major scale's fourth note is an E? The answer is B. The fourth note of a B major scale is an E note.

Start on the fourth note in a B major scale and play from the E note to the next E note and you have E Lydian. As you can see below, B major and E Lydian are both constructed from the same notes.

E Lydian = E, F#, G#, A#, B, C#, D#

B Major = B, C#, D#, E, F#, G#, A#

Remember, it's all about MOOD and EMPHASIS when playing in the modes. Which note you start on and emphasize produces the different moods and sound textures of each mode.

Below are two common shapes for Lydian. One has the low root note on the low E-string and the other has the low root on the A-string. As you can see they are almost identical to a major scale except your play a #4.

Find these patterns fast by using your first finger on the low root. Learn all the shapes to play Lydian across the whole neck as per the major scale lessons in this eBook.

**Low E-string root
first finger**

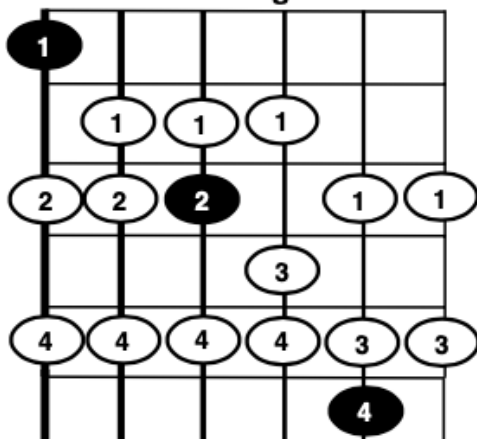

**A-string root
(first finger)**

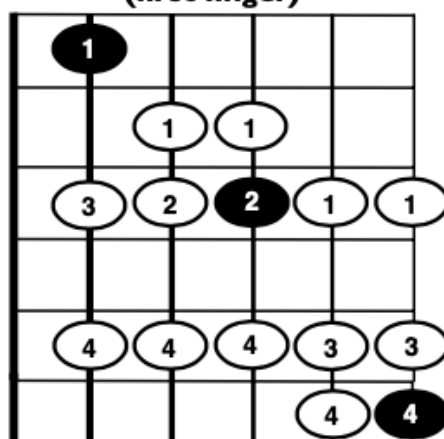

KEY POINTS:

Lydian is always the 4th mode of any major key.

Starting on and emphasizing the 4th note of any major scale produces the Lydian Mode.

Lydian is often the mode of choice over major 7th and major 9th chords.

Remember, it's all about MOOD and EMPHASIS when playing in the modes

The Modes Of The Major Scale - Phrygian

The Phrygian Mode produces a very distinctive dark, exotic, Spanish type of sound. Often its called the Spanish Minor Scale. **Phrygian is a minor mode and is always the 3rd mode in any major key.**

Often you will hear the Phrygian mode played in hard rock, metal, fusion, and flamenco guitar. You don't hear this mode utilized as often as Aeolian or Dorian, but it is super fun to experiment with and get some killer exotic tones.

You can try this mode over minor chords, but it can sound a tad exotic, some may say dissonant. Often its the mode of choice when you see a b2 chord, or play it over a m7 chord, minor triad, or power chords.

Phrygian has only one note different than the Aeolian. Phrygian has a flatted 2nd, (b2), while Aeolian has a natural 2nd. The scale degrees of Phrygian are 1, b2, b3, 4, 5, b6, b7.

Phrygian is always the 3rd mode in any major key. To play in E Phrygian ask yourself what major scale's third note is a E? The answer is C. The third note of a C major scale is E. Play C major scales but emphasize the E notes. C major and E Phrygian consist of the same notes.

C Major scale - C, D, E, F, G, A, B
E Phrygian - E, F, G, A, B, C, D

Remember, it's all about MOOD and EMPHASIS when playing in the modes. Which note you start on and emphasize produces the different moods and sound textures of each mode.

Below are two common shapes for Phrygian. One has the low root note on the low E-string and the other has the low root on the A-string. Find these patterns fast by using your first finger on the low root.

Don't think of "shapes" or "positions" as modes. Get in the habit of looking at the entire fretboard as the vehicle for the mode, not just a certain position.

Learn the mode and its interval structure across the entire fretboard. Start with the scales below, but learn all the positions as per the major scales lessons in this eBook to play across the entire neck. Try to get creative with this mode and let your ear guide you to what sounds best - enjoy!

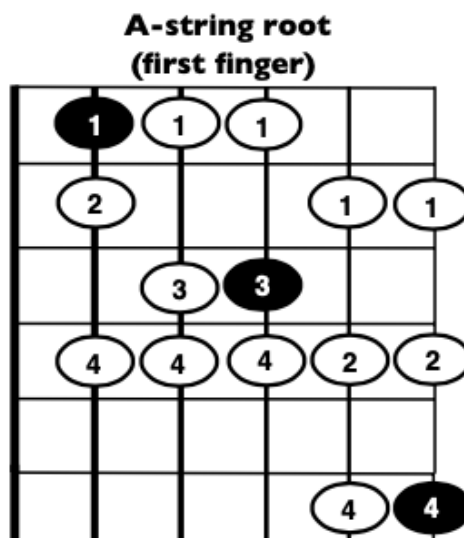
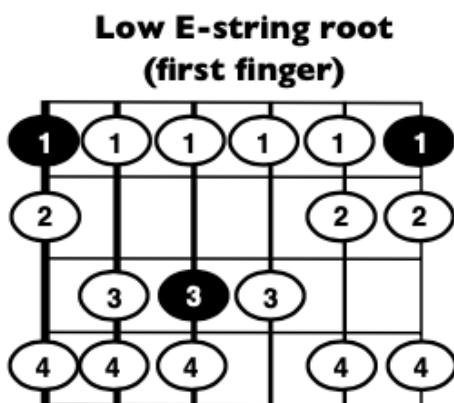

KEY POINTS:

Phrygian is always the 3rd mode of any major key.

Starting on and emphasizing the 3rd note of any major scale produces the Phrygian Mode.

Remember, it's all about MOOD and EMPHASIS when playing in the modes.

The Modes Of The Major Scale - Dorian

The Dorian Mode is a seven-note scale often used in blues, rock, and many other musical genres. **Dorian is considered a minor mode and is always the 2nd mode in any major key.**

Dorian produces a mystical, minor sound that is a bit sweeter than Aeolian. The Dorian scale degrees are 1, 2, b3, 4, 5, 6, and b7. There is only one note difference between Dorian and Aeolian - the 6th.

I find myself using Dorian all the time as it sounds awesome in rock, hard rock, blues, and even in some jazzy scenarios.

Utilize Dorian over all the chords in a minor key jam when there is a major IV chord or a minor ii chord. You can also use Dorian over minor type chords when treating each chord as a "separate event".

Remember Dorian is the 2nd mode in any major key. To play A Dorian the question is what major scale's 2nd note is an A note? The answer is G major. A Dorian would be converted back to its parent scale of G major.

To play in A Dorian start on the 2nd note in a G major scale and play from the A note till the next A note and you have A Dorian. You are playing a G major scale from the A to the A and voila', you have A Dorian.

Playing G major scales starting on the 2nd note and emphasizing the A notes, not the G notes, produces A Dorian. This establishes the tonal center as A. G major and A Dorian are constructed from the same notes.

G Major scale – G, A, B, C, D, E, F#

A Dorian scale - A, B, C, D, E, F#, G

Below are two common shapes for Dorian. One has the low root note on the low E-string and the other has the low root note on the A-string. Find these patterns fast using your first finger on the low root.

Start with these scales below, then learn all the shapes to play Dorian across the neck. Refer to the major scale lessons taught earlier in this eBook.

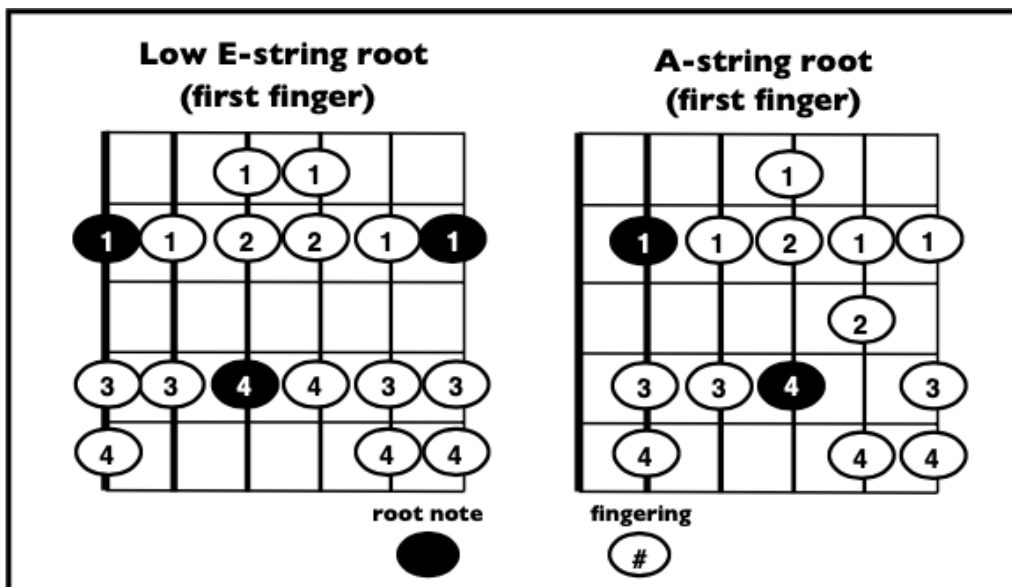

KEY POINTS:

Dorian is always the 2nd mode of any major key.

Starting on and emphasizing the 2nd note of any major scale produces the Dorian Mode.

Dorian has one note difference than Aeolian. Dorian has a natural 6th while Aeolian has a b6. Dorian has a bit more sweeter, mystical sound than Aeolian.

The Modes Of The Major Scale - Mixolydian

The Mixolydian Mode is a seven-note scale often used in blues and rock. **Mixolydian is considered a major mode and is always the 5th mode in any major key.** Often its the mode of choice played over dominant chords, like dominant 7ths and 9ths.

Mixolydian is basically a major scale, (Ionian Mode), but with a b7. The scale degrees are 1,2,3,4,5,6,b7. Try this mode over dominant chords like 7th and 9th chords when treating each chord as a “*separate event*”.

Mixolydian is the 5th mode and the key is to shift the tonal center to the root of the mode. For example, to play G Mixolydian over a G7 chord ask yourself what major scale’s fifth note is a G? The answer is C.

The fifth note of a C major scale is a G note. Play C major scales over a G7 chord but emphasize the G notes for G Mixolydian. C major and G Mixolydian consist of the same notes:

C Major scale - C, D, E, F, G, A, B

G Mixolydian - G, A, B, C, D, E, F

This is an incredibly useful mode, especially for blues and jazz playing. To play E Mixolydian over an E7 chord ask yourself what major scale’s fifth note is a E? The answer is A.

The fifth note of a A major scale is an E note. Play A major scales over an E7 chord but emphasize the E notes. A major and E Mixolydian consist of the same notes.

Remember, it’s all about MOOD and EMPHASIS when playing in the modes. Which note you start on and emphasize produces the different moods and sound textures of each mode.

Below are two common shapes for Mixolydian. One has the low root note on the low E-string and the other has the low root on the A-string. Find these patterns fast by using your first finger on the low root and try them in various keys over the appropriate jam tracks - and have fun!

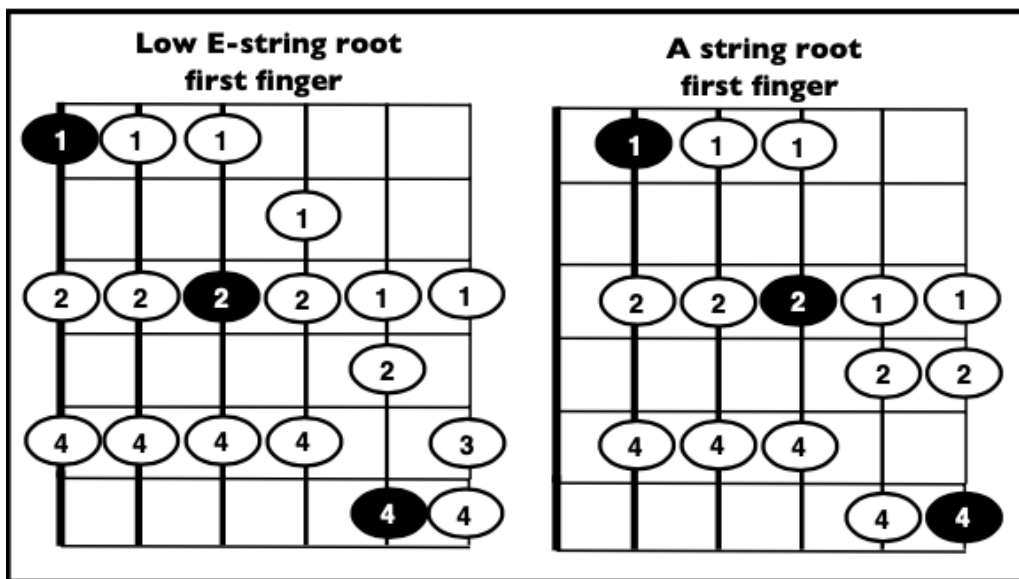

KEY POINTS:

Mixolydian is always the 5th mode of any major key.

Starting on and emphasizing the 5th note of any major scale produces the Mixolydian Mode.

Mixolydian is often the mode of choice over dominant 7th chords.

Soloing Review Tips

Key points to determine soloing avenues:

1. **Determine the key signature** - Most of the time you will be soloing in minor key or major key. Knowing the key is the first step. Even when you are noodling around on the guitar, always know what key you are playing. Many guitarists make the mistake of just looking solely at the key – that won't give you all the needed information.

2. **Analyze the chord progression** - It's the chords that give you the complete roadmap to what you can utilize for soloing and improvisation. Analyzing the chords is critical to get the full lead guitar picture. Knowing the key is only part of the equation. The chords provide the road map for what scales, modes, and arpeggios you will want to utilize. The chords also point to the strong notes to land on, resolve to, and emphasize.

Remember that you can mix soloing techniques. Mix what “relates to all” with treating each chord as a “separate event”. Treat each chord as a “separate event”, then switch it up and play what “relates to all”.

At times you can also use both major and minor scale elements as well as modal playing. In those examples you can throw a bunch of different soloing applications into the soup.

A critical key in unlocking all the potential of these scales and modes is in learning their interval structure and listening to the mood of each one and how it sounds over a given chord. This way you will know when it is appropriate to apply each in a given soloing or improvisation scenario.

Two goals of lead guitar playing:

1. **Compliment the song** – in the end, no matter how great a solo is, it's the song that will be remembered. Play for the song, not for yourself.

2. **Draw people into your solo** – you want the listener to latch onto what you are playing and to be on the edge of their seat wondering, “what will they play next?”

Take the listener on a musical journey with ups and downs, great emotion, and passion. Play from the heart while telling a story, and always be aware of melody.

Remember to experiment, its okay to bend and break the “rules”. Nothing is etched in stone. Work on developing your own style and pulling from all your musical influences.

Keep up all that hard work on that guitar and keep honing your skills and refining your art - YOU CAN DO IT!

KEY POINTS:

It's the chords that give the complete roadmap to all the soloing and improvisation options.

Take the listener on a musical journey - draw them into your solo and have them latch onto what you are playing.

Even when you are just noodling around on the guitar, always know what key you are playing in.



I hope this eBook, coinciding video lessons, and jam tracks help you along in your guitar journey. As a teacher my goal is to educate, empower, and inspire students to help them reach their guitar and musical goals.

I wish you the best in all your musical endeavors. Please feel free to email me any questions at the email address listed below. Keep up all the hard work on that guitar and remember that your guitar playing is an evolution. It takes time, patience, and dedication. Go after your dreams like your life depends on it.....because it does!

Take care, rock on, and swing for the fences!

David Taub

Next Level Guitar

TheNextLevelGuitar@yahoo.com

“Rock On Good People” - on YouTube

“Epic Guitar Instruction” - on YouTube

Check out our full-on video instructional website at:

<http://www.nextlevelguitar.com>

The site has 2000+ video lessons, written lessons, jam tracks, and much more! Its a complete structured guitar curriculum for all level players and all genres of music - check it out today!

Questions? Email us at thenextlevelguitar@yahoo.com
Check out all our DVD and other instructional products at
<http://www.nextlevelguitar.com/shop>

© 2017-2024 all rights reserved - Unauthorized replication or distribution is prohibited
Next Level Guitar Inc. ®